

20 NOV. 1979

MINISTERIE VAN DEFENSIE  
KONINKLIJKE LANDMACHT  
LANDMACHTSTAF / BLS

GEHEIM

30 NOV. 1979

's-Gravenhage, 19 NOV. 1979

Afdeling / sectie: INL/VEIL

Nr. 541 / P/Geh

Exh. .... 197...., nr. ....

Onderwerp:

Exh. .... 197...., nr. ....

Supintrep/WPLASK - su deel 1: Orig  
Sovjet last

Korte inhoud:

aanbieding publicatie  
WP Lask su deel 1: Orig  
Sovjet last + 1<sup>e</sup> opg. van wijz.

..... afschr. brief ..... voor .....

..... afschr. brief ..... voor .....

Ter kennisneming aan

AAN:

afd. datum ontv. datum verz. paraaf

vooraf

Verzendlijst

secr tik

HINLA tt

secr verz

Medezenden

achteraf

bijlage

INLA

ARCHIEF

Dat. en par.

ARCH

Ontworpen door P. Marchetti

19/11-11

Uitgaand stuk

Vervolgparafen

SIEXX Htd.

GEHEIM

getypt door J. Nederbragt op 21-11

gecoll. door H. de Vries op 21-11

Overgelegde  
r.a.

Registratie  
datum en  
paraaf

Terugverzochte  
r.a.

Het dik omlinjde gedeelte door de  
ontwerper in te vullen.

C. VERHEY  
Verzonden op/door

Indice: 12.13  
71.63.12

vernietigen in

X

1D - II - 771299 - 725444\* - 125

30 NOV. 1979

wijzigingen, renvoaien,  
aantekeningen enz.

ontwerp

uw kenmerk:

uw brief van:

**GEHEIM**

*24/11*

Hierbij doe ik U toekomen het in de verzendlijst  
vermelde aantal exemplaren van de publicatie  
"Warschaupakt Landstrijdkrachten - Sovjet-Unie"  
deel 1: Organisatie Sovjet Landstrijdkrachten,  
*Abnede de 1<sup>e</sup> ofpart van wijzigingen  
op deze publicatie.*

CLAS  
voor deze  
Hoofd sie INLA  
1kol

C. KLOOS

Verzendlijst behorende bij brief CLAS,  
nr. 541/ /Geh van.....

VERZENDLIJST:

aan:	ex.nr. brief	ex.nr. bijlage
C- 1 Lk	- 1	1 t/m 130
NTC	- 2	131 - 132
SMID	- 3	133
C-COKL	- 4	134 t/m 139
Dir HKS	- 5	140
Gouv KMA	- 6	141
H-MARID	- 7	142
H-LUID	- 8	143
C-Mar(bur 2.2)	- 9	144
<u>Intern:</u>		
INL A	- 10	145 t/m 196
Archief	- 11	197

**GEHEIM**

*Genr 199  
Med. by INLA*

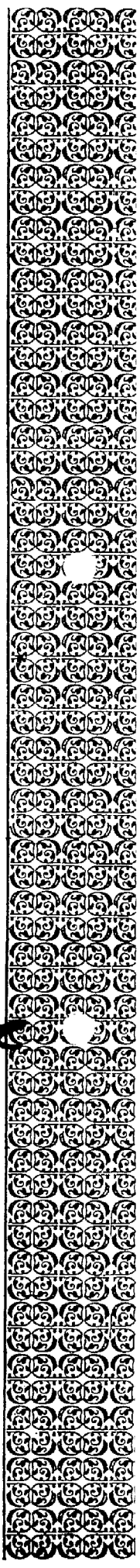

**MINISTERIE VAN DEFENSIE**  
**LANDMACHTSTAF**

CORRESPONDENTIE - ADRES: POSTBUS 90711, 2509 LS 's-GRAVENHAGE

Dit stuk mag niet worden  
vermenigvuldigd dan met  
toestemming van Hoofd

Afd. INL/VEIL

Afdeling / Sectie: INL/VEIL  
Thérèse Schwartzestraat 15  
Telefoon: 070 - 73 ..... / 245370 tsl

**Net-minute**  
GEHEIM

Ex. nr: **11**  
Men wordt verzocht bij beantwoording datum en  
nummer van deze brief nauwkeurig te vermelden

Aan

zie verzendlijst

bijlagen:

uw brief van

uw kenmerk

ons nummer

541/P/Geh

onderwerp: Supintrep WP Lask  
S.U. deel 1:  
Org Sovjet Lask

's-Gravenhage,

**30 NOV. 1979**

Hierbij doe ik U toekomen het in de verzendlijst vermelde aantal  
exemplaren van de publicatie "Warschaupakt Landstrijdkrachten -  
Sovjet-Unie deel 1: Organisatie Sovjet Landstrijdkrachten" als-  
mede de le opgave van wijzigingen op deze publicatie.

DE CHEF VAN DE LANDMACHTSTAF  
VOOR DEZE:  
HET HOOFD VAN DE SECTIE INL A  
DE LUITENANT-KOLONEL

  
C. KLOOS

GEHEIM

1e Opgave van wijzigingen op de publicatie

"WARSCHAUPAKT LANDSTRIJDKRACHTEN

SOVJET-UNIE DEEL 1 ORGANISATIE"

NO.: 541/P/Geh

- blz 27 , twee NBCbats wordt één NBCbat
- " 35 regel 3 kolom 14, wordt 1
- " 35 regel 4 kolom 14, wordt 1
- " 35 regel 5 kolom 14, wordt 1
- " 35 regel 21 kolom 14, 1 wordt 4
- " 35 regel 21 kolom 18, wordt 2
- " 35 regel 21 kolom 19, 2 wordt 1
- " 35 regel 21 kolom 20, doorhalen
- " 56 , onder symbool van artcogp schrijven: co en contr
- " 63 , onder symbool van artcogp schrijven: co en contr
- " 64 regel 18 kolom 38, wordt 4
- " 77 , tekst onder symbool van vbd/verkcie, rd/rdr intcep  
wordt rd/rdrpeil en rdintcep
- " 110 kolom 19, BMD met SMALL FRED wordt BMP M-1975 (SMALL  
FRED)
- " 113 regel 21 kolom 18, 98 wordt 38

Net-minute  
GEHEIM

Nr.: 541/P/Geh

Ex.nr.: 194

LANDMACHT INLICHTINGDIENST

WARSCHAUPAKT

LANDSTRIJDKRACHTEN

SOVJET-UNIE

DEEL 1

ORGANISATIE

SOVJET LANDSTRIJDKRACHTEN

Datum van uitgifte:

30 NOV. 1979

GEHEIM

# Net-minute

GEHEIM

ex.nr. 194

1e Opgave van wijzigingen op de publicatie

"WARSCHAUPAKT LANDSTRIJDKRACHTEN

SOVJET-UNIE DEEL 1 ORGANISATIE"

NO.: 541/P/Geh

- blz 27 , twee NBCbats wordt één NBCbat
- " 35 regel 3 kolom 14, wordt 1
- " 35 regel 4 kolom 14, wordt 1
- " 35 regel 5 kolom 14, wordt 1
- " 35 regel 21 kolom 14, 1 wordt 4
- " 35 regel 21 kolom 18, wordt 2
- " 35 regel 21 kolom 19, 2 wordt 1
- " 35 regel 21 kolom 20, doorhalen
- " 56 , onder symbool van artcogp schrijven: co en contr
- " 63 , onder symbool van artcogp schrijven: co en contr
- " 64 regel 18 kolom 38, wordt 4
- " 77 , tekst onder symbool van vbd/verkcie, rd/rdr intcep  
wordt rd/rdrpeil en rdintcep
- " 110 kolom 19, BMD met SMALL FRED wordt BMP M-1975 (SMALL  
FRED)
- " 113 regel 21 kolom 18, 98 wordt 38

SOVJET LANDSTRIJDKRACHTEN

DEEL 1

1. De slagorde van de Sovjet Landstrijdkrachten bestaat uit vier delen:
  - Deel 1 : Organisatie Sovjet Landstrijdkrachten
  - Deel 2 : Slagorde GSVG
  - Deel 3 : Slagorde SGV, TsGV en YuGV
  - Deel 4 : Slagorde MD'n - Sovjet Unie
  
2. Deze publicatie werd samengesteld door de Landmacht Inlichtingen-dienst en geeft voor de Koninklijke Landmacht de nationale mening weer.
  
3. De inhoud is ontleend aan gegevens uit diverse bronnen. Niets uit de inhoud mag worden beschouwd als een bevestiging van informatie, zolang niet onomstotelijk vast staat, dat die informatie afkomstig is van een bron waaruit bij het opstellen van deze publicatie niet reeds werd geput.
  
4. Aanvragen voor toezending van exemplaren van deze publicatie dienen langs de hiërarchieke weg te worden gericht aan Hoofd Inlichtingen en Veiligheid CLAS/BLS.
  
5. Hiermede is de volgende publicatie vervallen:
  - "Sovjet-blok Landstrijdkrachten GSVG"
  - deel 1 - uitgiftedatum 27 oktober 1969

augustus 1979

Nr en datum wijziging	Wijziging aange- bracht dd	Wijziging aange- bracht door	Paraaf



I N H O U D S O P G A V E

	<u>blz</u>
Voorwoord	1
Aantekenblad aangebrachte wijzigingen	2
Inhoudsopgave	3
Inleiding tot de organisatie	4
Front	6
Leger	27
Tankdivisie	46
Gemechaniseerde infanteriedivisie	51
Luchtlandingsdivisie	109
Luchtlandingsstormbrigade	116
Marine-infanterieregiment	118

INLEIDING TOT DE ORGANISATIE1. ALGEMEEN

De in deze publicatie opgenomen organigrammen en organisatie-tabellen zijn bedoeld om een overzicht te geven van de organisatie van de Sovjet landstrijdkrachten. Daar er echter in de organisatie van deze landstrijdkrachten vele variaties voorkomen is in deze publicatie getracht een standaard organisatie weer te geven, waarvoor de meest moderne Groep van Strijdkrachten, de GSVG, model heeft gestaan. De vermelde aantallen personeel en materieel zijn gebaseerd op beschikbare gegevens. Indien niet over gegevens werd beschikt, zijn internationaal geaccepteerde aantallen vermeld.

2. FRONT

Een front heeft geen vaste samenstelling. Het wordt in oorlogstijd geformeerd en zal dan bestaan uit een aantal legers en fronttroepen. In de organigrammen is de samenstelling weergegeven van de GSVG. In de organisatietabellen is een overzicht gegeven van eenheden die deel kunnen uitmaken van de fronttroepen.

3. LEGER

Bij de Sovjet landstrijdkrachten komen twee soorten legers voor, n.l. tankleger en gemechaniseerde infanterielegers. Een leger heeft geen vaste samenstelling, het zal bestaan uit een aantal tank- en/of gemechaniseerde infanteriedivisies en legertroepen. In het organigram is de samenstelling van een leger weergegeven zoals dit voorkomt bij de GSVG. In de organisatietabel is een overzicht gegeven van eenheden die deel kunnen uitmaken van de legertroepen.

De organigrammen en organisatietabellen van enkele eenheden die zowel deel kunnen uitmaken van de legertroepen als van de fronttroepen zijn opgenomen bij het front(SCUDbrig, SA-4 brig, Pontbrreg, en Amfgnbat).

4. TANKDIVISIE

De eenheden die deel uitmaken van een tankdivisie komen ook voor in een gemechaniseerde infanteriedivisie. Voor de organigrammen en organisatietabellen van deze gesubordineerde eenheden wordt verwezen naar de gemechaniseerde infanteriedivisie.

5. GEMECHANISEERDE INFANTERIEDIVISIE

Bij deze divisie zijn de organigrammen en organisatietabellen opgenomen van de eenheden die deel uit kunnen maken van een gemechaniseerde infanteriedivisie en van een tankdivisie. Aangezien bij deze divisies een SA-6 reg, een SA-8 reg of een luareg(S-60) voor kan komen, zijn alle drie organisatievormen opgenomen. Het organigram en de organisatietabel van het luareg(S-60) zijn terug te vinden bij het front.

6. LUCHTLANDINGSDIVISIE

Deze divisie komt uitsluitend voor bij militaire districten in de Sovjet-Unie.

7. LUCHTLANDINGSSTORMBRIGADE

Deze eenheid komt ook uitsluitend voor bij militaire districten in de Sovjet-Unie.

8. MARINE-INFANTERIEREGIMENT

Ook deze eenheid komt alleen voor bij militaire districten in de Sovjet-Unie.

FRONT

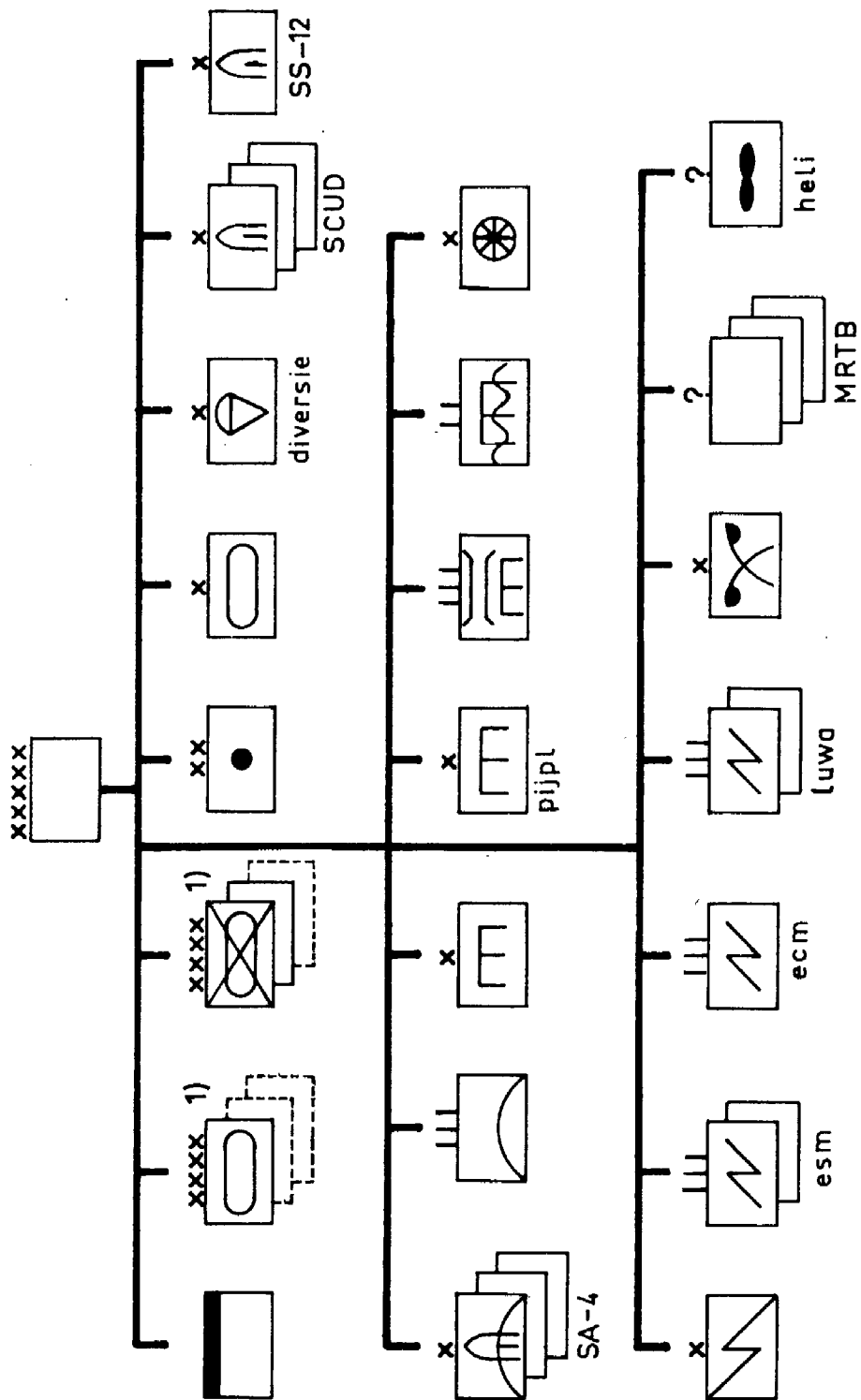

1) Aantal legers variabel







ARTILLERIEDIVISIE

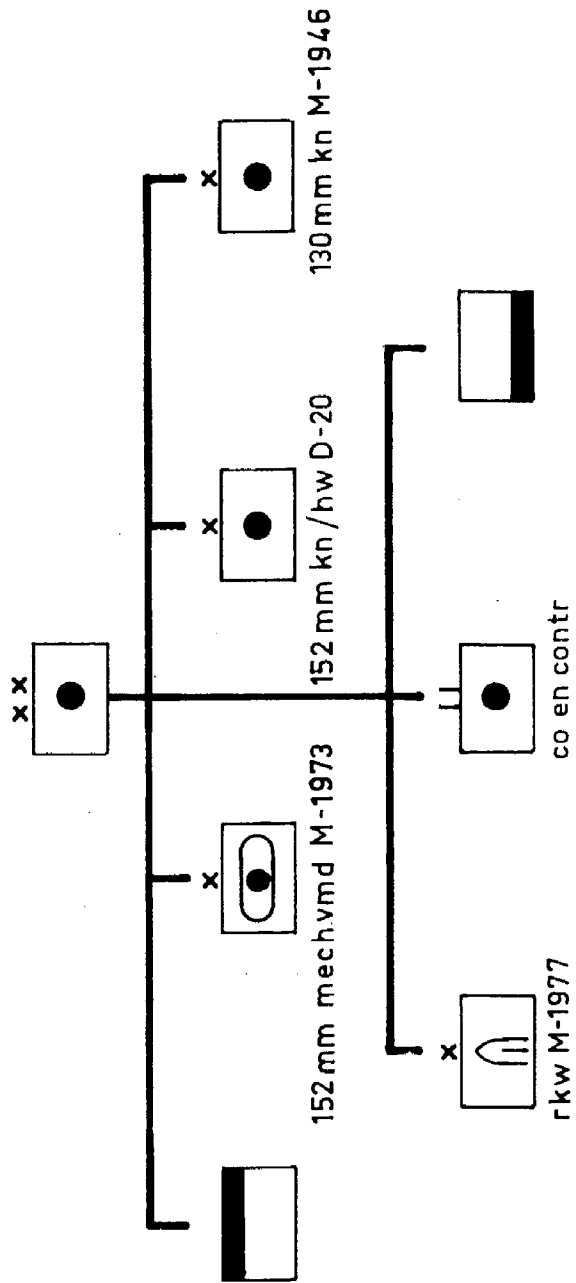





	7	8	9	10	11	12	13	14	15	16	17	18	19	20	21	22	23	24	25	26	27	28	29	30	31	32	33	34	35	36	37	38	39	40	41																			
BTM/MDK-2			BAT/BAT-K																																																			
E-305Y																																																						
ARS-124/14																																																						
DDA-53/66																																																						
R-104 H-105/108/109/114 of R-107/111																																																						
R-118 BM3																																																						
R-123M																																																						
R-125/145																																																						
R-126																																																						
R-311																																																						
R-401M/403M/405																																																						
SMAR-2/2A/6 (PORK THROUGH)																																																						
AHSOM-2/2P (SMALL TANK)																																																						
ARMS-1 (END TRAY)																																																						
NRS-1 (POLE DISH)																																																						

Rege	Eanheid	PERSONEEL					
		Offn	Overigen	Totaal			
1	Staf						
2	Artesenfd						
3	Artbrig (getr)						
4	Artbrig (getr)						
5	Artbrig (mech)						
6	Rkvrbrig						
7	Diensten						
8							
9							
10							
11							
12							
13							
14							
15							
16							
17							
18							
19							
20							
21	Totaal	2	2	2	15	12	13
		105	12	126	45	13	5
		10					
		6	3				
		3					
		12					

FORM 10-45-47-77

SCUD BRIGADE

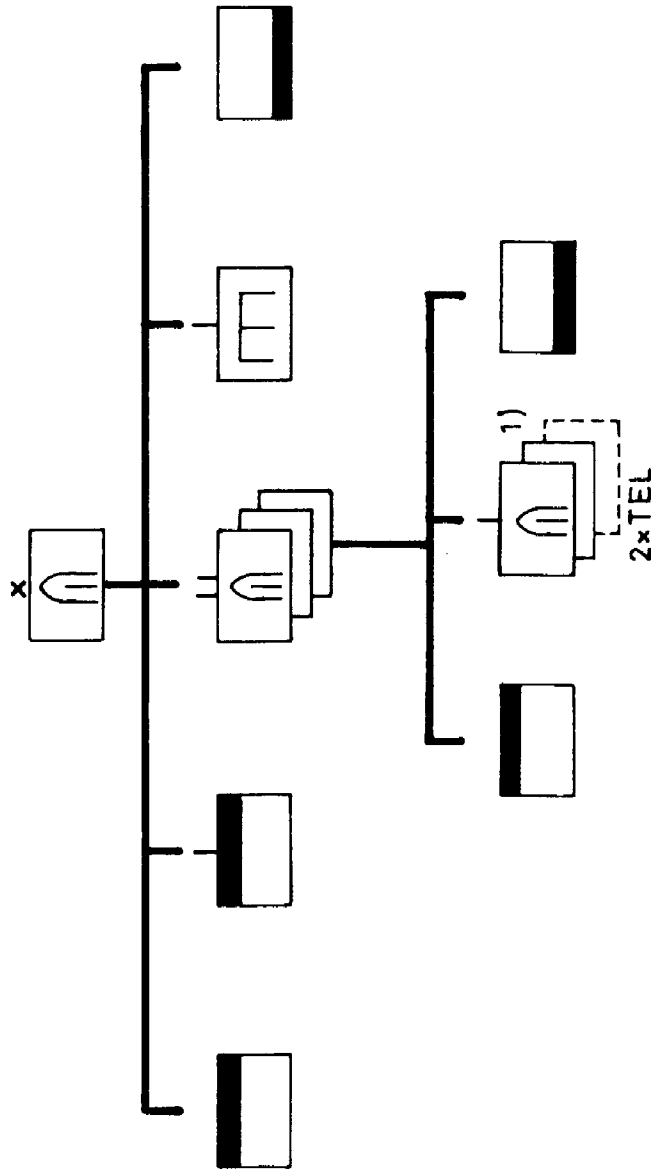

1) Op frontniveau 6x TEL per afd



	7	8	9	10	11	12	13	14	15	16	17	18	19	20	21	22	23	24	25	26	27	28	29	30	31	32	33	34	35	36	37	38	39	40	41						
Abv keuken	2																																								
Abv water																																									
Abv benzine																																									
Abv diverse						4																																			
T-54T/55T																																									
BTM/MDK-2									3	6																															
BAT/BAT-M																																									
ARS-12U/14															4																										
R-102M/103M																			1																						
R-105/108/109/114 of R-107/111																			1																						
R-118 BM3																				5																					
R-311																									1																
R-312/313/314/323																									1																
R-405																																									
ARMS-1 (END PRAY)																																									

1	2	3	4	5	6
Regel	Eenheid				
			PERSONEEL		
1	Staf				
2	Stafbt				
3	SCUDaaf				
4	SCUDaaf				
5	SCUDaaf				
6	Gacie				
7	Diensten				
8					
9					
10					
11					
12					
13					
14					
15					
16					
17					
18					
19					
20					
21	Totaal				

GEHEIM

SA -4 BRIGADE

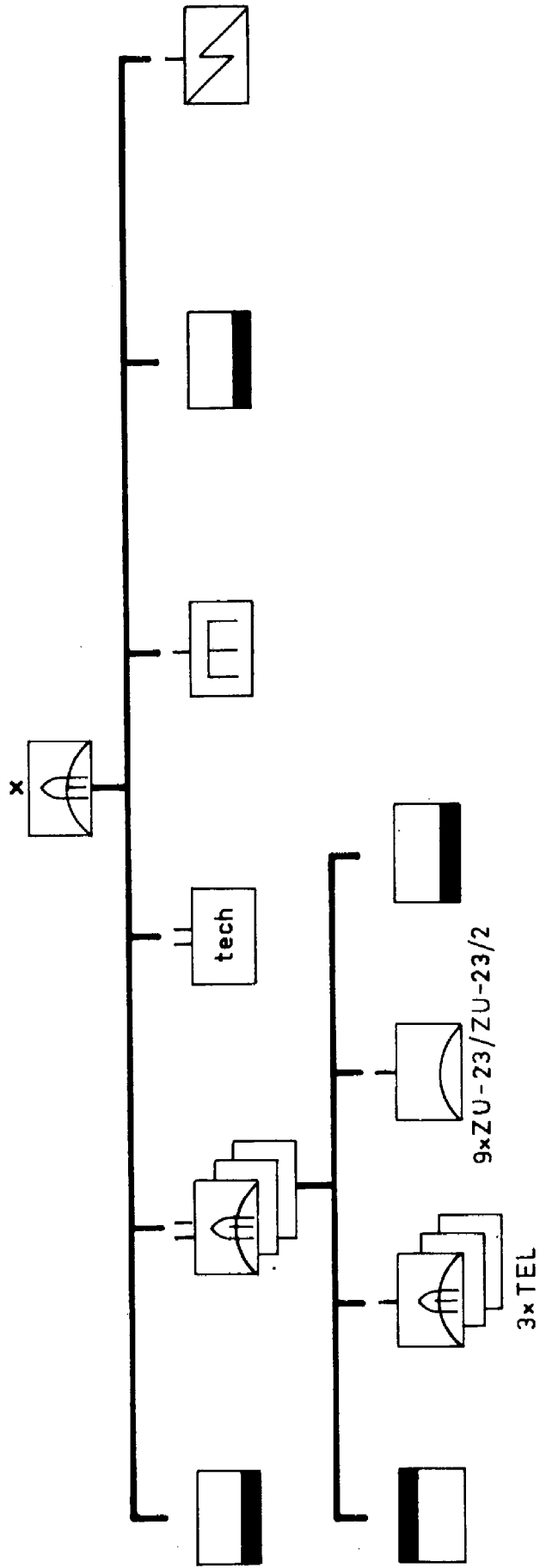

GEHEIM

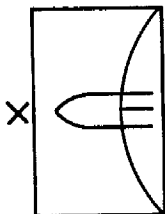

SA-4

1	2	3	4	5	6	PERSONEEL		7	8	9	10	11	12	13	14	15	16	17	18	19	20	21	22	23	24	25	26	27	28	29	30	31	32	33	34	35	36	37	38	39	40	41										
						Offn	Overigen																																				Totaal									
Regel	Eenheid																																																			
1	Staf		40	25	65																																															
2	Ybacie		10	40	50																																															
3	SA-4 afd		25	200	225																																															
4	SA-4 afd		25	200	225																																															
5	SA-4 afd		25	200	225																																															
6	Techafd		20	200	220																																															
7	Groef		2	40	42																																															
8	Diensten		10	45	55																																															
9																																																				
10																																																				
11																																																				
12																																																				
13																																																				
14																																																				
15																																																				
16																																																				
17																																																				
18																																																				
19																																																				
20																																																				
21	Totaal		157	950	1107																																															





LUCHTAFWEERREGIMENT

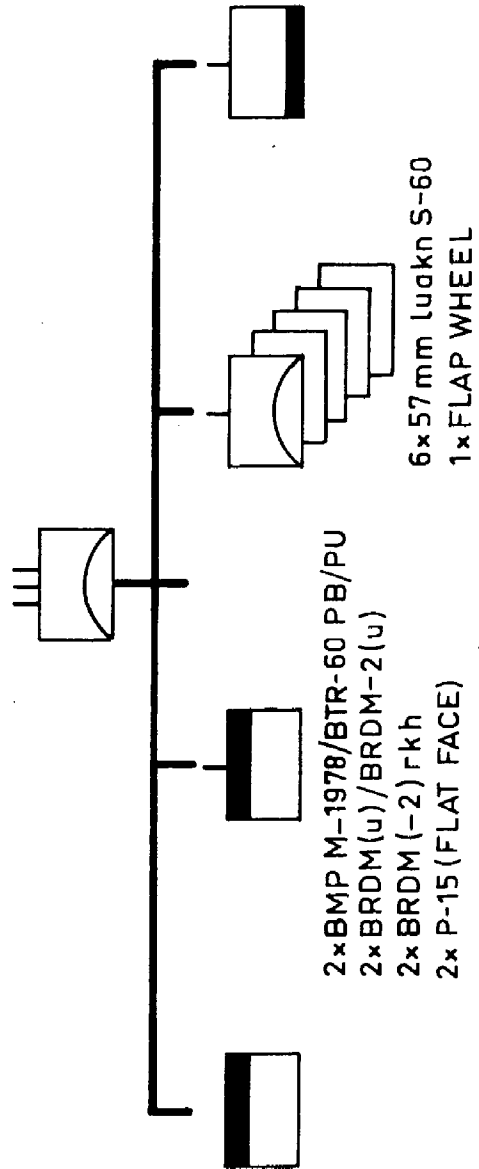



1	2	3	4	5	6	7	8	9	10	11	12	13	14	15	16	17	18	19	20	21	22	23	24	25	26	27	28	29	30	31	32	33	34	35	36	37	38	39	40	41															
																																									Regel	Eenheid	PERSONEEL	Offn/Overigen	Totaal										
1	1	Staf	2	1																																																			
2	2	Stafbt	6	2																				2																															
3	3	Luabt	4	1																					1																														
4	4	Luabt	4	1																					1																														
5	5	Luabt	4	1																					1																														
6	6	Luabt	4	1																					1																														
7	7	Luabt	4	1																					1																														
8	8	Vzgbt	1																																																				
9	9																																																						
10	10																																																						
11	11																																																						
12	12																																																						
13	13																																																						
14	14																																																						
15	15																																																						
16	16																																																						
17	17																																																						
18	18																																																						
19	19																																																						
20	20																																																						
21	21	Totaal	29	2	6								1																																										

R-105/108/109/114  
of R-107/111  
R-118 BM3  
R-123M  
R-311

R-15 (PLATFACE)  
PLAT WHEEL

PONTONBRUGREGIMENT

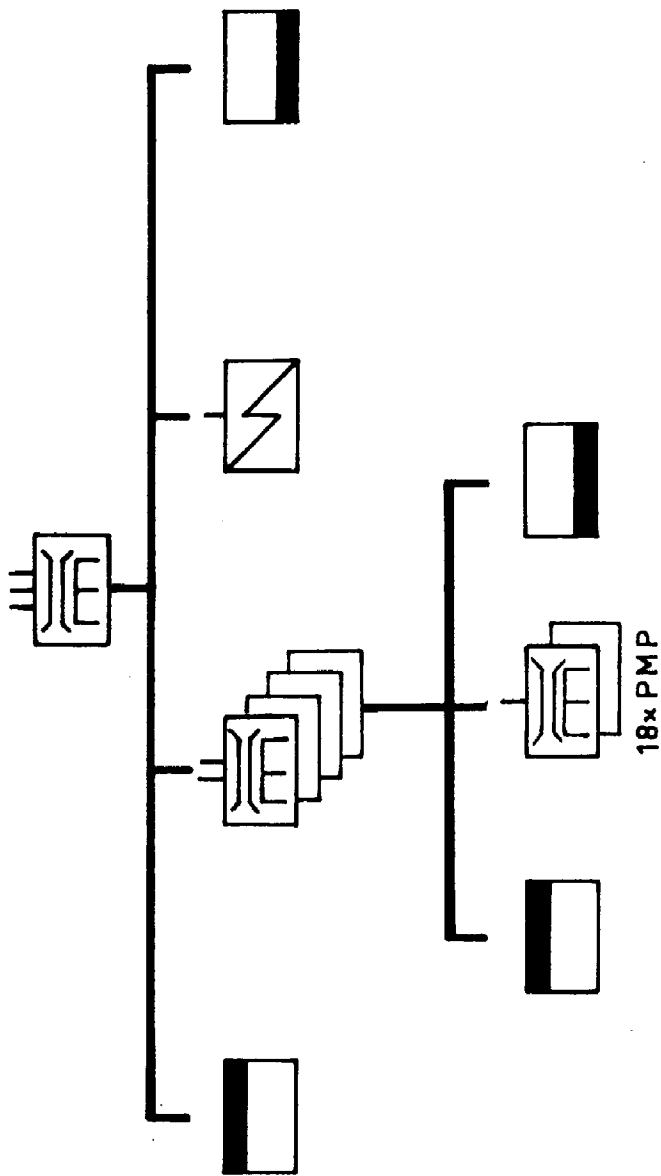



	7	8	9	10	11	12	13	14	15	16	17	18	19	20	21	22	23	24	25	26	27	28	29	30	31	32	33	34	35	36	37	38	39	40	41
		K-61/PTS/PTS-M		BMP op KRAZ-214/255B		KMS	BMK-150/150/BMK-1	BTM/MDK-2	BAT/BAT-M	IMR	D-144		H-104	H-105/108/109/114 of H-107/111	H-118 BM3	H-123M	H-125/145	H-311	H-401M/403M/405																

1	2	3	4	5	6
Regel	Eenheid	PERSONEEL			
		Offin Overig			
1	Staf				
2	Vbdele				
3	Pontbrbat	6	36		
4	Pontbrbat	6	36		
5	Pontbrbat	6	36		
6	Pontbrbat	6	36		
7	Diensten	3			
8					
9					
10					
11					
12					
13					
14					
15					
16					
17					
18					
19					
20					
21	Totaal	27	144	4	48
				3	3
				7	3
				5	3
				17	7
				1	1
				9	1
				1	1

AMFIBISCH GENIEBATALJON

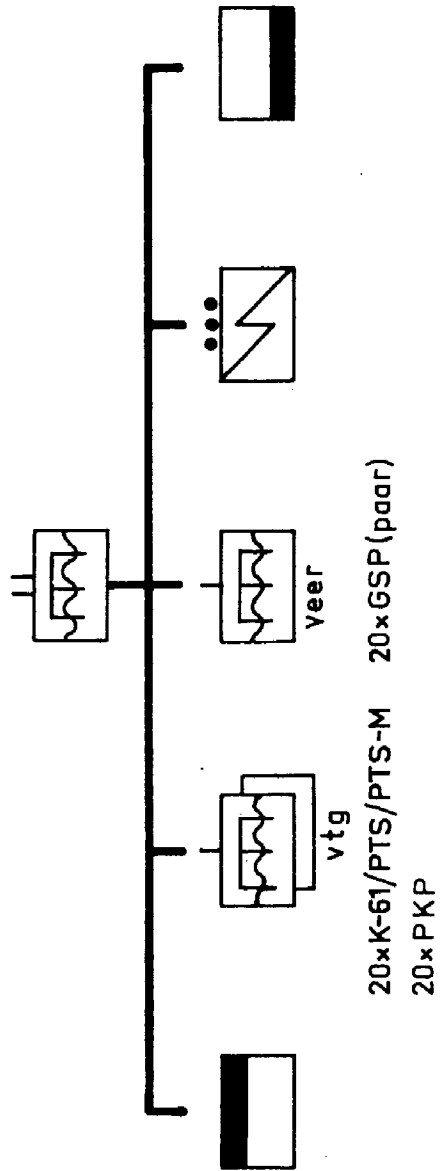





LEGER

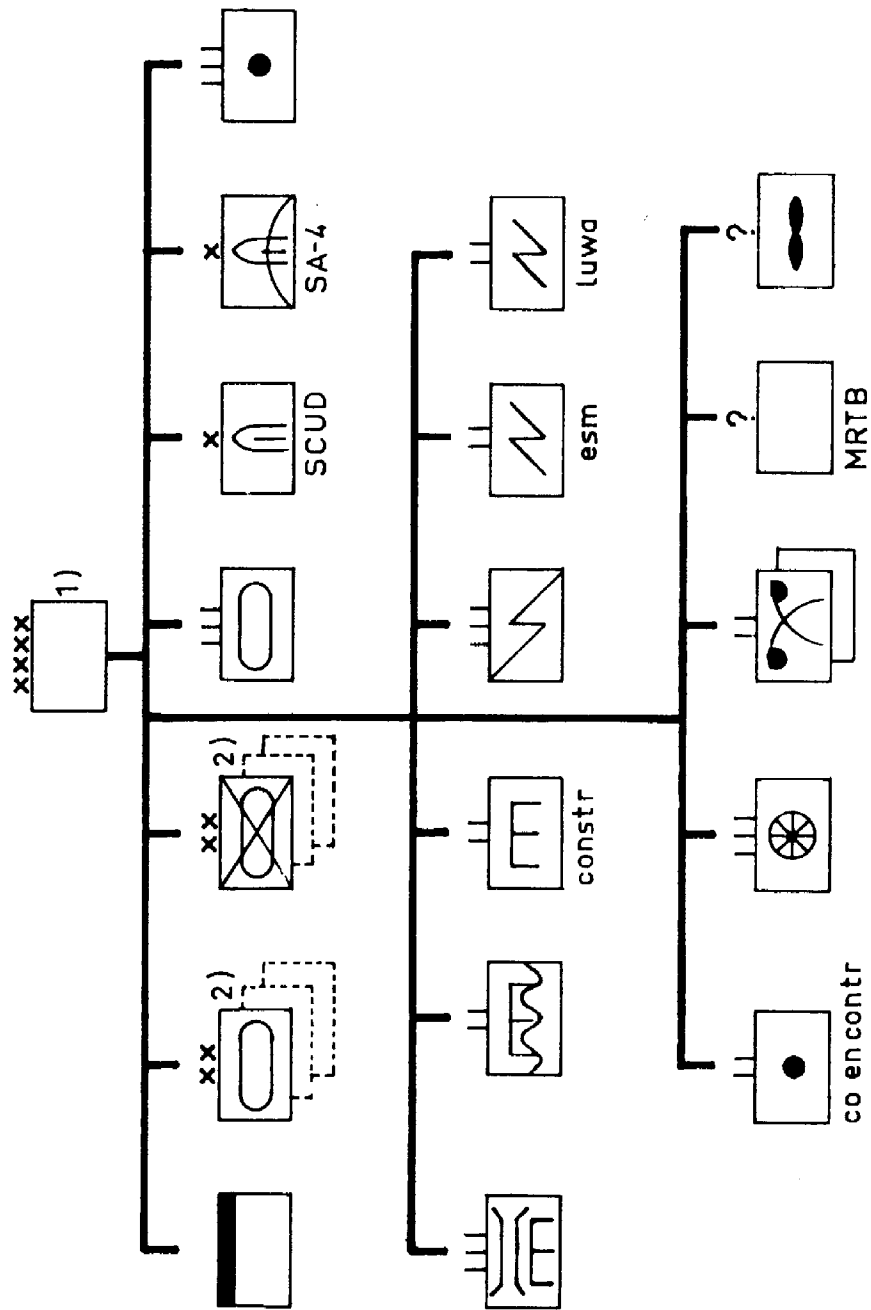

- 1) Tank- of gemechaniseerd leger
- 2) Aantal divisies variabel







TANKREGIMENT (zelfst)

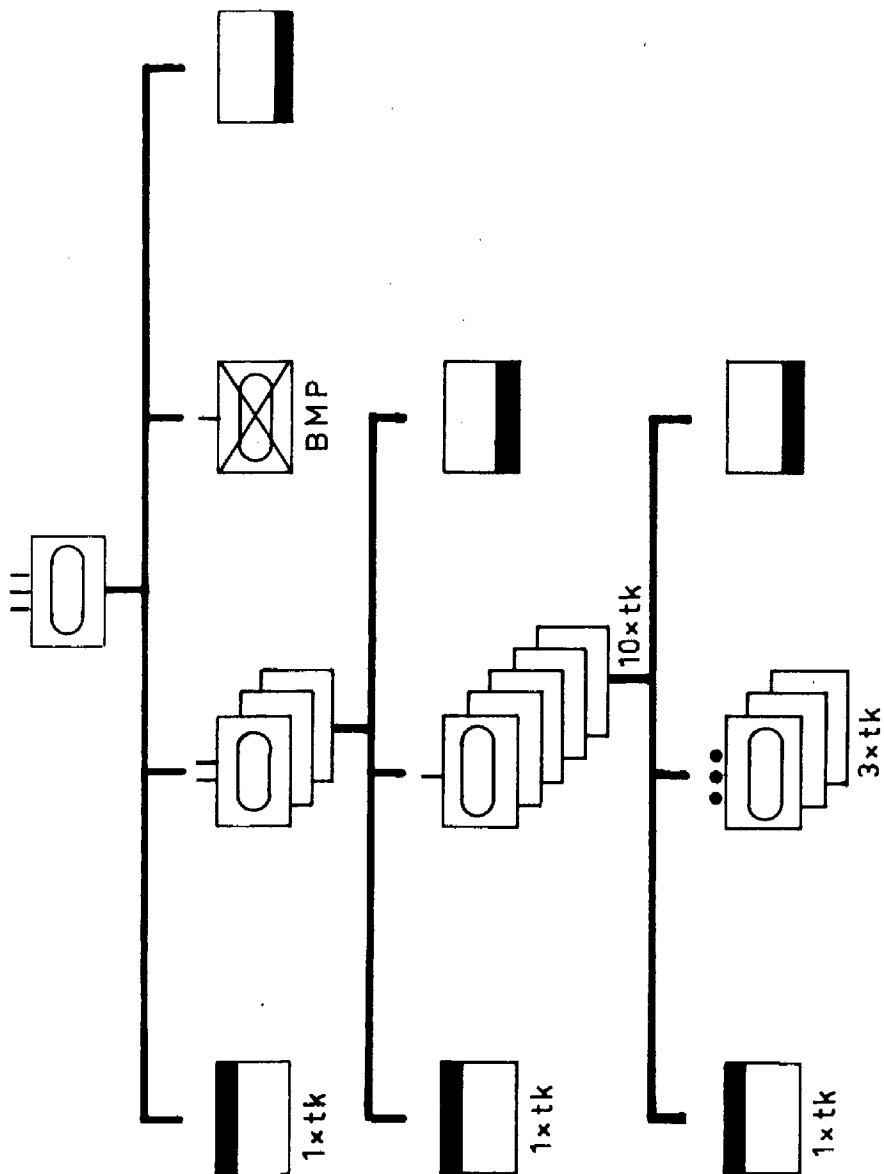

	7	8	9	10	11	12	13	14	15	16	17	18	19	20	21	22	23	24	25	26	27	28	29	30	31	32	33	34	35	36	37	38	39	40	41
			SA-7			T-55/64	BMP-1	BMP M-1974	BMP M-1978/ PR-60 PR/PT	BRDM-2(U)	BTR-50 PR M-1975	UAZ-69/469	GAZ-66	ZIL-130/131/157 URAL-375D/377	Wkplan	Benkan	Rou	Zan	Takan	Waterauto	PAK-170/200	Ahv Kenken	Ahv water	Ahv benzine	Ahv diverse	T-54/55T	R-105/108/109/114 of R-107/111	R-118BM3	R-123M	R-125/145	R-126M	R-311			

(zelfst)

Rege	Eenheid	PERSONEEL				
		Off	In	Overige	Totaal	
1	Staf	20	10	30		
2	Tkbat	25	225	250		
3	Tkbat	25	225	250		
4	Tkbat	25	225	250		
5	Mechele	5	100	105		
6	Diensten	10	85	95		
7						
8						
9						
10						
11						
12						
13						
14						
15						
16						
17						
18						
19						
20						
21	Totaal	110	870	980		

ARTILLERIEREGIMENT ( I r )

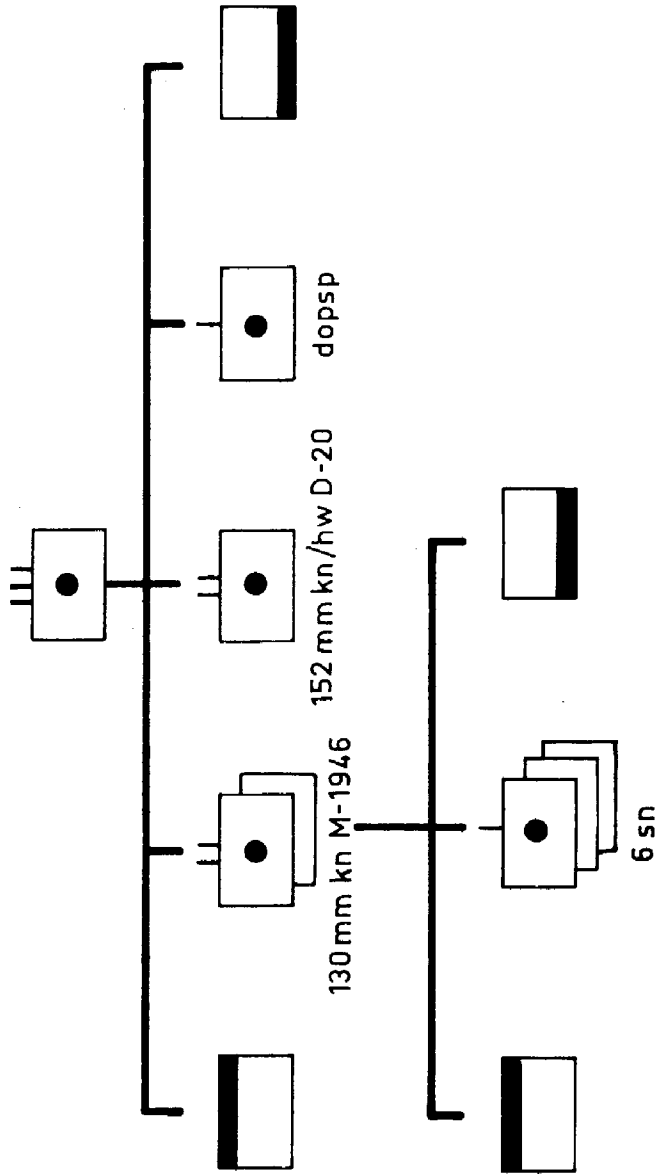

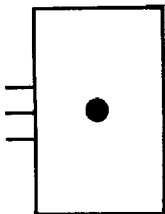

(LR)

Regel	Eenhed	PERSONEEL					
		Offn	Overigen	Totaal			
1	Staf	20	30	50			
2	Dopsbdt	10	91	101			
3	Artafd(M-46)	21	282	303			
4	Artafd(M-46)	21	282	303			
5	Artafd(D-20)	21	291	312			
6	Diensten	6	182	188			
7							
8							
9							
10							
11							
12							
13							
14							
15							
16							
17							
18							
19							
20							
21	Totaal	99	1158	1257	36	18	

	7	8	9	10	11	12	13	14	15	16	17	18	19	20	21	22	23	24	25	26	27	28	29	30	31	32	33	34	35	36	37	38	39	40	41			
130 mm kn M-1946																																						
152 mm kn/hv D-20																																						
BMP M-1975 (SMALL PRSD)					1																																	
BMP M-1976 (BMP M-1975) (SMALL PRSD)						1																																
MT-LB M-1975 (BIG PRSD)							1																															
Arttrekker (AT-S/URAL/KRAZ)														2									1															
UAZ-69/469														4	1	1	5	2					2															
UAZ-69 rkh														4	1	1	5	2																				
UAZ-452																																						
GAZ-66																																						
URAL-375D/377																																						
Wkplan																																						
Benzan																																						
Ran																																						
Zan																																						
Watermto																																						
Ahv kouken																																						
Ahv water																																						
Ahv benzine																																						
Ahv diverse																																						
T-54/55T																																						
ARS-12U/14																																						
DDA-53/66																																						
DKV																																						

G E M E I N

G E M E I N





GEHEIM

VERBINDINGSREGIMENT

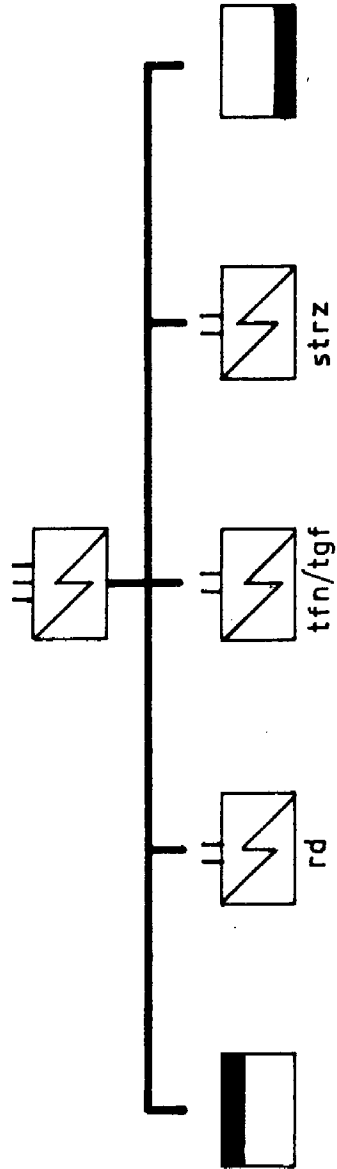

GEHEIM



GEHEIM

VERBINDINGSINLICHTINGENBATALJON

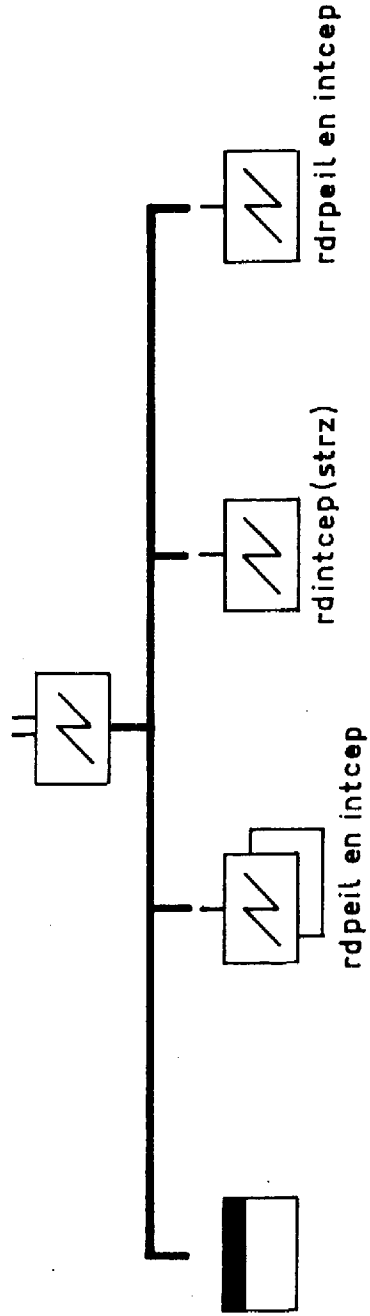

GEHEIM



GEHEIM

LUCHTWAARSCHUWINGSBATALJON

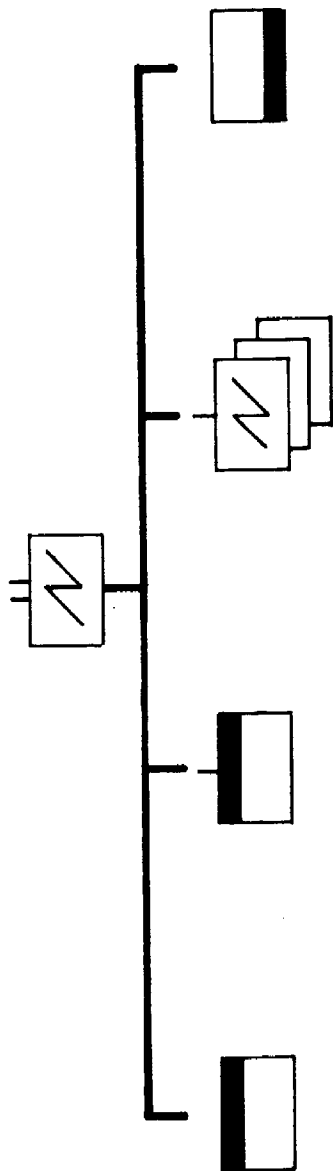

GEHEIM

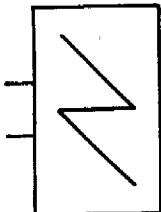

DMND

Regel	Eenheid	PERSONEEL					Totaal
		4	5	6	7	8	
1	Staf	7	12	19			
2	Stafbt	3	76	79			
3	Edroie	6	64	70			
4	Edroie	6	64	70			
5	Edroie	6	64	70			
6	Diensten	2	40	42			
7							
8							
9							
10							
11							
12							
13							
14							
15							
16							
17							
18							
19							
20							
21	Totaal	30	320	350			
7							
8	TAZ-69/469				1	22	48
9	GAZ-66						
10	ZIL-130/131/151/171-375D/377						
11	Benzau						
12	Zau						
13	Ahv keuken						
14	Ahv water						
15	Ahv benzine						
16	Ahv diverse				8		
17							
18							
19							
20							
21							
22							
23	R-102M/103M					2	8
24	R-105/108/109/114 or R-107/111					2	8
25	R-118 BM3						
26	R-154						6
27	R-311						6
28							
29	THIN SKIN						4
30							
31	P-12(SPOON REPT)						4
32	P-15(PLAT FACE)						4
33	P-15D(SQUAT EYE)						4
34	P-40(LONG TRACK)						4
35							
36							
37							
38							
39							
40							
41							

NBC BATALJON

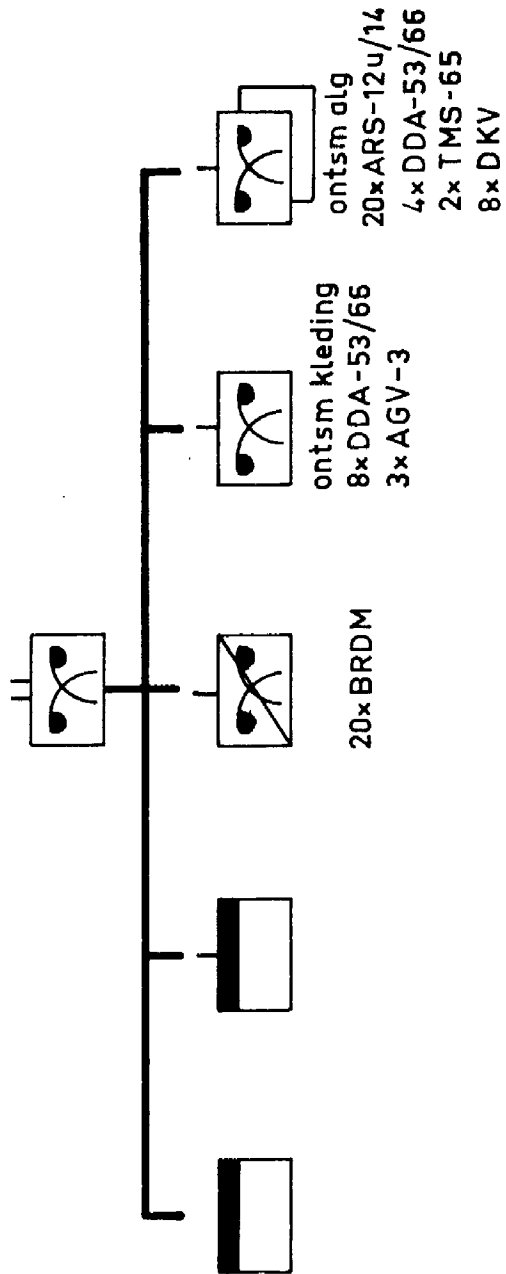



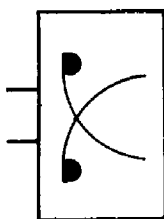

1	2	3	4	5	6	PERSONEEL		7	8	9	10	11	12	13	14	15	16	17	18	19	20	21	22	23	24	25	26	27	28	29	30	31	32	33	34	35	36	37	38	39	40	41										
						Offn	Totaal																																													
Regel	Eenheid																																																			
1	Staf		3	8	11																																															
2	Stafolie		3	70	73																																															
3	Bbeverkoie		6	80	86																																															
4	Ontsmoie (kleding)		5	80	85																																															
5	Ontsmoie (alg)		5	90	95																																															
6	Ontsmoie (alg)		5	90	95																																															
7																																																				
8																																																				
9																																																				
10																																																				
11																																																				
12																																																				
13																																																				
14																																																				
15																																																				
16																																																				
17																																																				
18																																																				
19																																																				
20																																																				
21	Totaal		27	418	445																																															

GEHEIM

TRANSPORTREGIMENT

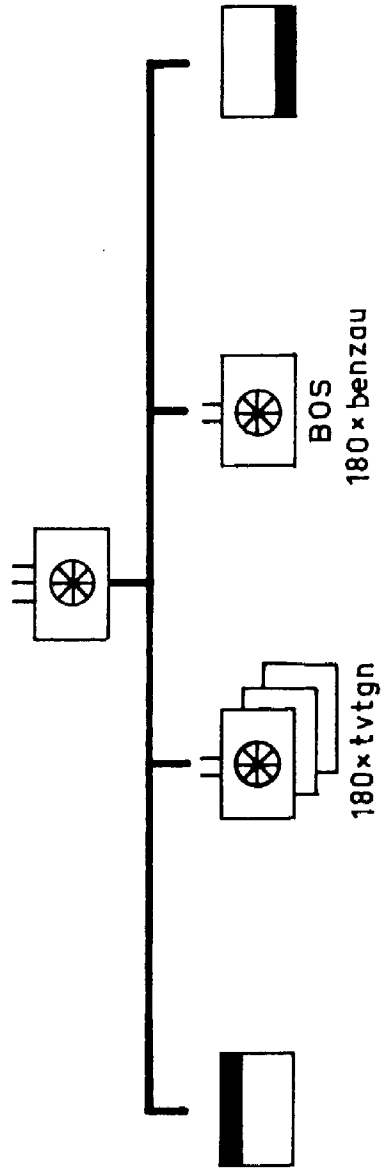

GEHEIM



TANKDIVISIE

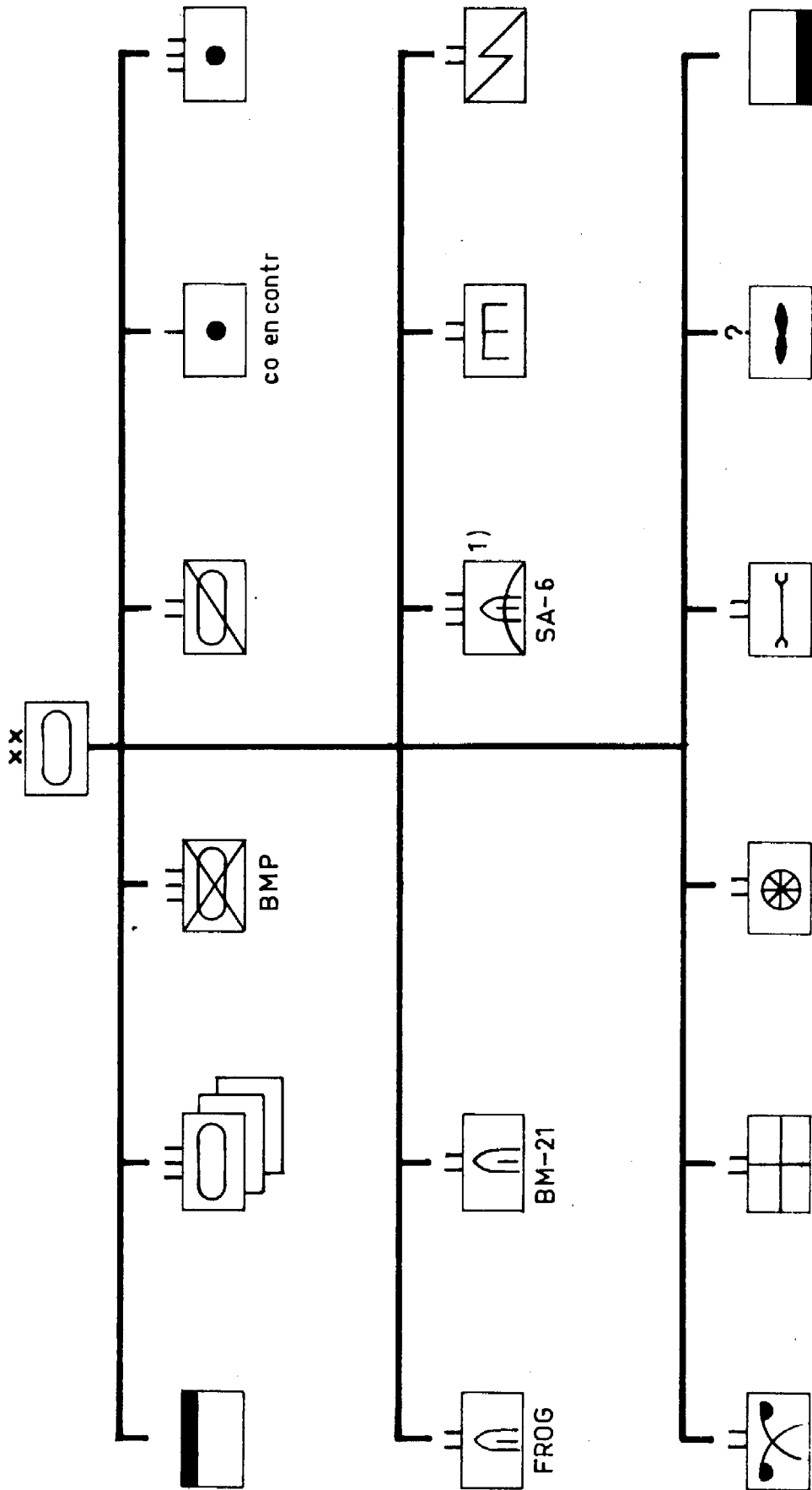

1) Ook een SA-8 reg of een luareg (S-60) is mogelijk





1	2	3	4	5	6																																				
						PERSONEEL																																			
Regel	Eenheid	Offn/Overigen/Totaal																																							
1	Staf																																								
2	Tkreg																																								
3	Tkreg																																								
4	Tkreg																																								
5	Meerreg (BMP)																																								
6	Verkbat																																								
7	Artcobt																																								
8	Artreg																																								
9	PROGafd																																								
10	Rkwafd																																								
11																																									
12	SA-6 reg																																								
13	Gnbat																																								
14	Vdbat																																								
15	Ncbat																																								
16	Gnkbata																																								
17	Tibat																																								
18	Ombat																																								
19	Heliehd																																								
20	Dienstea																																								
21	Totaal																																								





GEMECHANISEERDE INFANTERIEDIVISIE

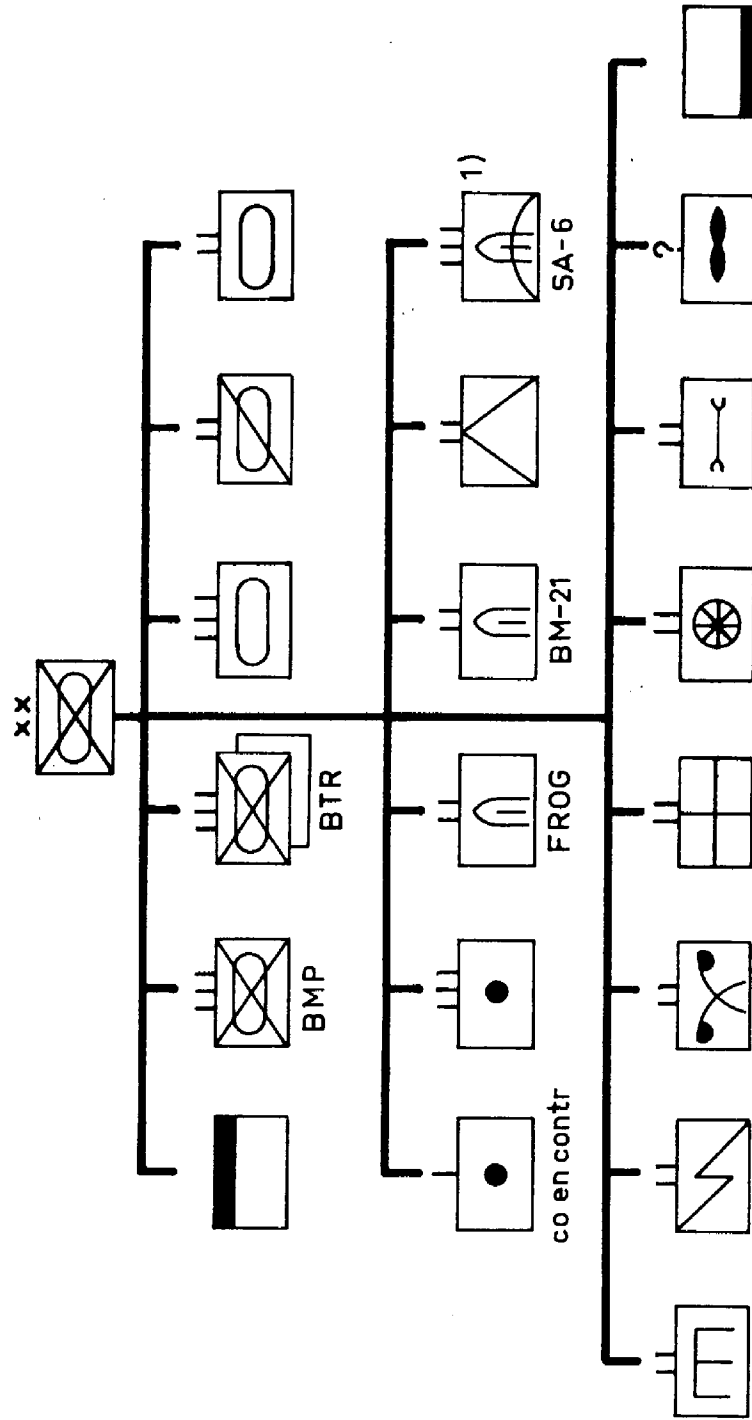

1) Ook een SA-8 reg of een luareg (S-60) is mogelijk

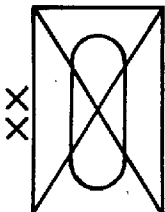

1	2	3	4	5	6	PERSONEEL	
						Offin	Overig/Totaal
1	Staf		90	150	240		
2	Mechreg(BMP)		180	2110	2290		
3	Mechreg (BMP) 2x		356	4436	4792		
4	Tkreg		122	1073	1195		
5	Verkbat		36	332	368		
6	Tkbat (zelfst)		35	280	315		
7	Artcobt		3	60	63		
8	Artreg		99	964	1063		
9	PROGard		23	153	176		
10	Rkward		22	240	262		
11	Atafd		23	246	269		
12	SA-6 reg <sup>1)</sup>		64	385	449		
13	Gnbat		29	387	416		
14	Vdbbat		20	285	305		
15	Ncbat		14	163	177		
16	Gnkbat		30	167	197		
17	Tbat		32	390	422		
18	Onhbat		19	221	240		
19	Helliehd		20	80	100	6	
20	Diensten		25	150	175		
21	Totaal		1242	12272	13514		

7	8	9	10	11	12	13	14	15	16	17	18	19	20	21	22	23	24	25	26	27	28	29	30	31	32	33	34	35	36	37	38	39	40	41			
B&I(HOPLITE)	120 mm nr	122 mm hv D-30	122 mm mechvmd M-1974	152 mm mechvmd M-1973	AP-3/5 op BRDM 100 mm atkn T-12/12A	BM-21	PROG-7 TEL	ZSU-23/4	SA-6 TEL 1)	SA-7	SA-9	T-55/62/64/72	BMP-1	BMP M-1974	BMP M-1975 (SMALL FRED)	BMP M-1976	BMP M-1978/ RTR-60PB/PV	BTR-60PB	BTR-60PB PAC	BRDM(v)/BRDM-2(v)	BRDM(-2) rkh	MP-LB (trekker)	MP-LB M-1975 (BIG FRED)	Artcovtg M-1974	BTR-50PK M-1975												

1) Ook een SA-8 reg of een Inareg (S-60) is mogelijk.



	7	8	9	10	11	12	13	14	15	16	17	18	19	20	21	22	23	24	25	26	27	28	29	30	31	32	33	34	35	36	37	38	39	40	41		
GSP (paar)		K-61/PTS/PTS-M	PKP	FME op K-AZ-214/255B	TMM	MTU-20/MT-55	KMS	BMK-130/150/BMK-7	BTM/MDK-2	BAT/BAT-M	E-305V	PZM	TMR	D-144	KMT-4/6	KMT-5	PMR-3/60	GMZ	MTK	DIM	ARS-120/14	DDA-53/66	TMS-65	DKV													

Regel	Eenheid	PERSONEEL																																
		4	5	6	Offn	Overig	Totaal																											
1	Staf																																	
2	Mechreg(BMP)																																	
3	Mechreg (BTR)2x	4	2																															
4	Tireg	8	4																															
5	Verkbat	4	4																															
6	Tkbat (selfst)			2																														
7	Artoobt																																	
8	Arzreg																																	
9	FROGafd																																	
10	Rkvalfd																																	
11	Atafd																																	
12	SA-6 reg					1																												
13	Gnbat	6	14	8	4	3	6																											
14	Ydbbat																																	
15	Mcbat																																	
16	Gnkbata																																	
17	Tbat																																	
18	Onhbat						1																											
19	Kellend																																	
20	Diensten																																	
21	Totaal	6	15	8	18	24	16	3	6	6	13	10	14	2	3	69	23	20	3	2	3	40	16	2	14									



# GEMECHANISEERD INFANTERIEREGIMENT (BMP)

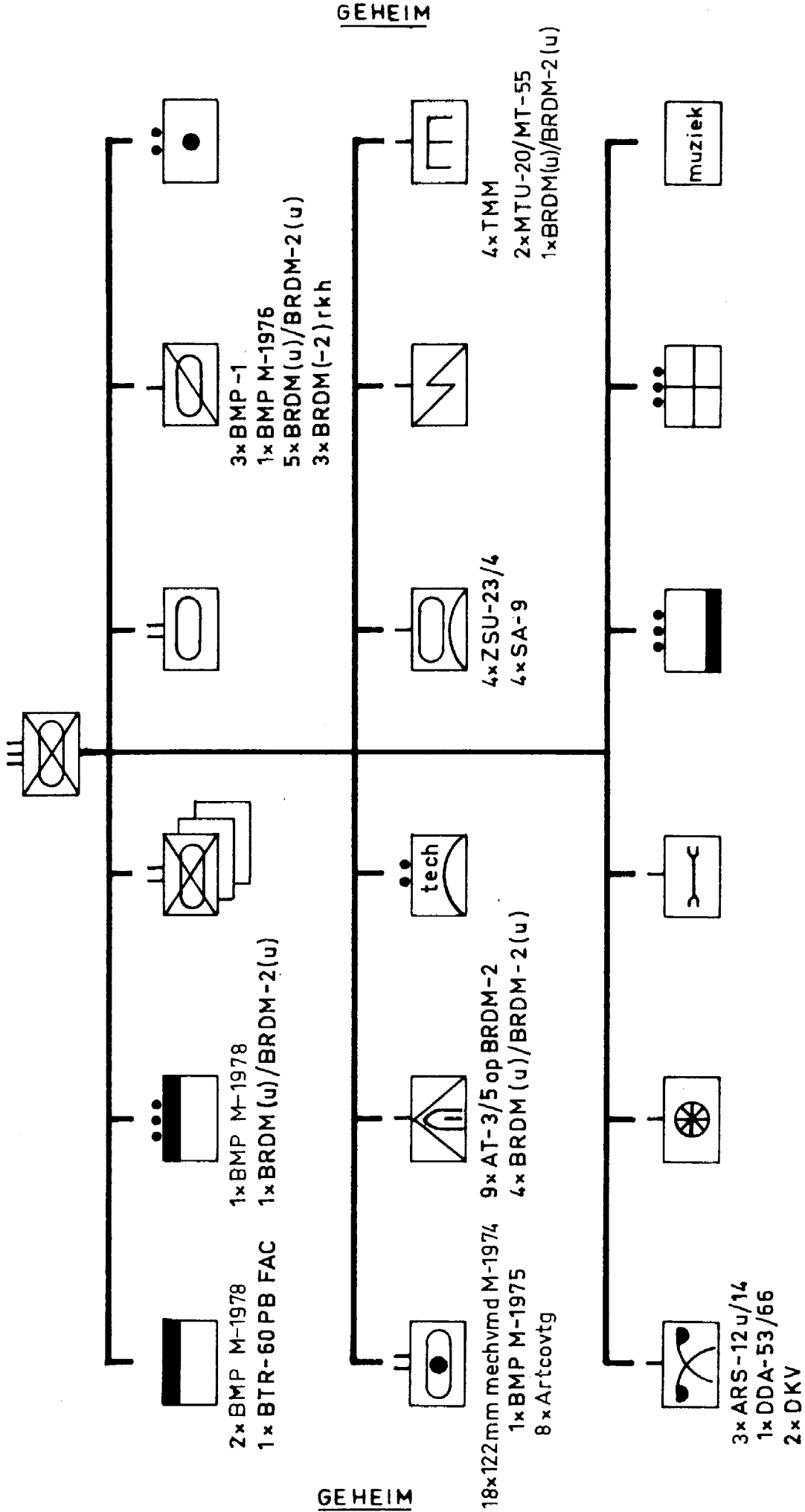

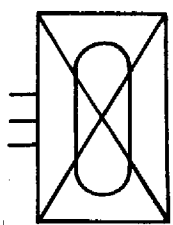

BMP

Regel	Eenheid	PERSONEEL					
		Offin	Overig	Totaal			
1	Staf	33	8	41			
2	Stafpel		29	29			
3	Mechbat (32)	72	1197	1269	162	81	
4	Tkbat	20	197	217			
5	Verkie	4	67	71		3	
6	Artoogp	1	12	13		1	
7							
8	Mechartafd	22	158	180	6		
9	Atole	4	36	40	9	9	
10	Inatechgp	2	12	14			
11	Mechluabt	4	46	50			
12	Vbdcie	2	48	50	2		
13	Gncie	4	65	69	2		
14	Nboeie	2	22	24			
15	Tcie	4	82	86	2		
16	Onheie	2	68	70			
17	Vsgpel		21	21			
18	Gnkpel	3	22	25			
19	Muziek	1	20	21			
20							
21	Totaal	180	2110	2290	162	110	9

	7	8	9	10	11	12	13	14	15	16	17	18	19	20	21	22	23	24	25	26	27	28	29	30	31	32	33	34	35	36	37	38	39	40	41		
PKM																																					
RFG-7																																					
AT-3/5 op BRDM-2																																					
120 mm nr																																					
122 mm mechverd M-1974																																					
ZSU-23/4																																					
SA-7																																					
SA-9																																					
T-55/62/64/72																																					
BMP-1																																					
BMP M-1974																																					
BMP M-1975 (SMALL WRED)																																					
BMP M-1976																																					
BMP M-1978/ BTR-60PB/PU																																					
BTR-60 PB PAC																																					
BRDM(u)/BRDM-2(u)																																					
BRDM(-2) rkh																																					
BTR-50PK M-1975																																					
VAZ-69/469																																					
VAZ-69 rkh																																					
VAZ-452																																					
GAZ-66																																					
ZIL-130/131/157																																					
URAL-375D/377																																					
KAZ-255 (dteplader)																																					
Wkplan																																					
Benzan																																					
Ran																																					
Zau(UAZ-451A)																																					
Takan																																					
Waterauto																																					
PAK-170/200																																					

	7	8	9	10	11	12	13	14	15	16	17	18	19	20	21	22	23	24	25	26	27	28	29	30	31	32	33	34	35	36	37	38	39	40	41		
M-12/URAI-3	Ahv keuken	Ahv water	Ahv benzine	Ahv diverse	T-54/55T	TMM	MTU-20/MT-55	BTM/MDK-2	BAT/BAT-M	E-305V	PZM	KMT-4/6	KMT-5	PMR-3/60	ARS-12D/14	DDA-53/66	DKV	R-105/108/109/114 of R-107/111	H-118 BM3	H-123M	H-125/145	H-126M	R-311	H-401M/403M	H-405	H-829	PSNR-1										

Regel	Eenheid	PERSONEEL																																
		3	4	5	6	Open	Totaal																											
1	Staf																																	
2	Stafpel																																	
3	Meebat(3x)																																	
4	Tkbat																																	
5	Verkoie																																	
6	Artcoogp																																	
7																																		
8	Meehartafd																																	
9	Atoie																																	
10	Luatechpp																																	
11	Meehluabt																																	
12	Vbdcie																																	
13	Gncie																																	
14	Wboeie																																	
15	Toie																																	
16	Onhoie																																	
17	Vagpel																																	
18	Gnkpel																																	
19	Musiek																																	
20																																		
21	Totaal	10	17	11	25	62	4	4	2	1	1	2	3	9	3	4	3	1	2	87	1	226	3	79		8	2	1	1	1				



GEMECHANISEERD INFANTERIEBATALJON (BMP)

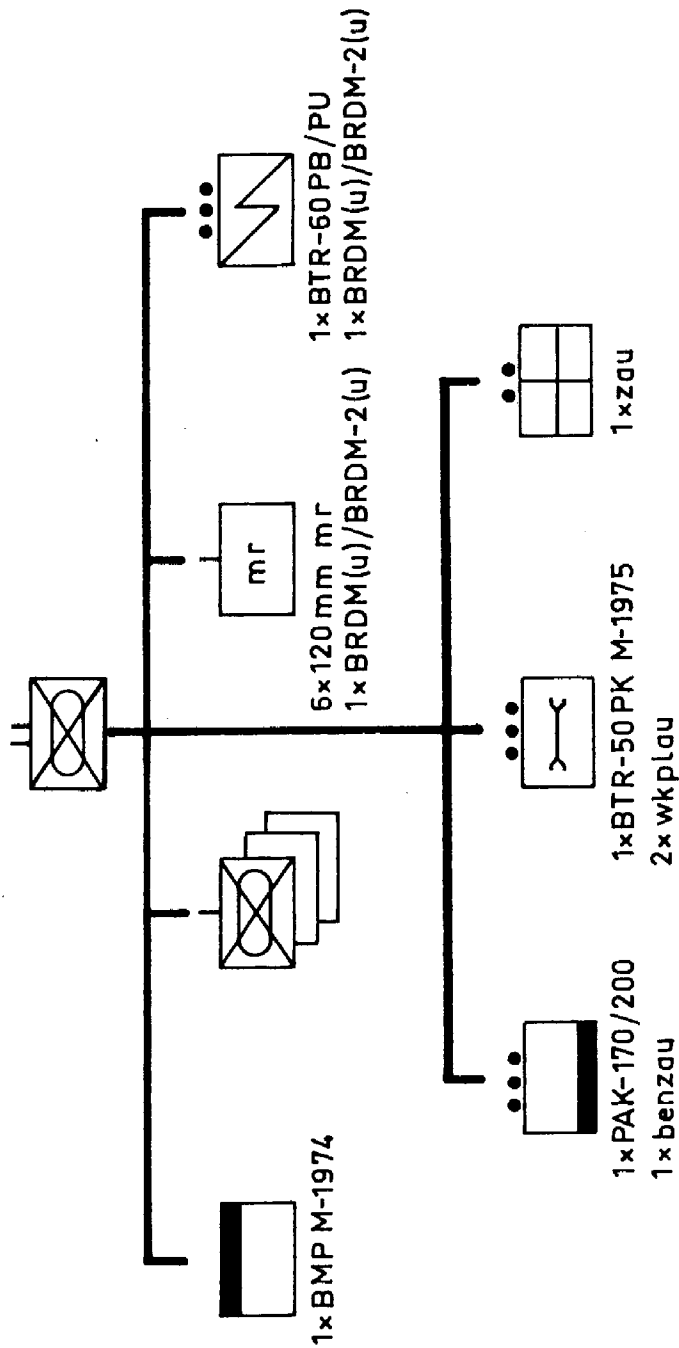

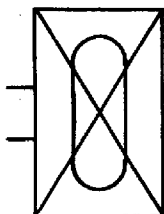

BMP

	Pt1	AKN	SYD	PKM	RPG-7	120 mm RT	SA-7	RMP-1	RMP M-1974	RBR-60R/PU	RBRM(u)/RBRM-2(u)	RTR-50PK M-1975	UAZ-69/469	GAZ-66	ZIL-130/131/157	WRplan	Komsan	Rau (GAZ-66)	Zau (UAZ-451A)	Ahv kenken	Ahv vater	Ahv benzine	Ahv diverse	PAK-170/200	H-105/108/109/114 of H-107/111	H-123M	H-126M	H-311	
																													3
Regel	PERSONEEL																												
	Eenheid	Offn	Overig	Totaal																									
1	Star	4	9	13	8	5			1				1	1											1	1	1		
2	Vbdpel	1	14	15	1	14				1			1													2	3	1	
3	Mecheie	5	100	105	17	70	3	3	1						1										1	10	4		
4	Mecheie	5	100	105	17	70	3	3	1					1											1	10	4		
5	Mecheie	5	100	105	17	70	3	3	1						1										1	10	4		
6	Mreie	4	50	54	6	49				1			1	7											1	1	4		
7	Vsgpel		13	13		13								4	4			1								2	1		
8	Onhpel		10	10		10						1				2													
9	Gakgp		3	3	1	2																							
10																													
11																													
12																													
13																													
14																													
15																													
16																													
17																													
18																													
19																													
20																													
21	Totaal	24	399	423	67	303	9	54	27	6	9	27	4	1	2	1	3	12	7	2	1	1	1	1	1	1	1	1	1

BMP 01-01-78

GEMECHANISEERDE INFANTERIECOMPAGNIE (BMP)

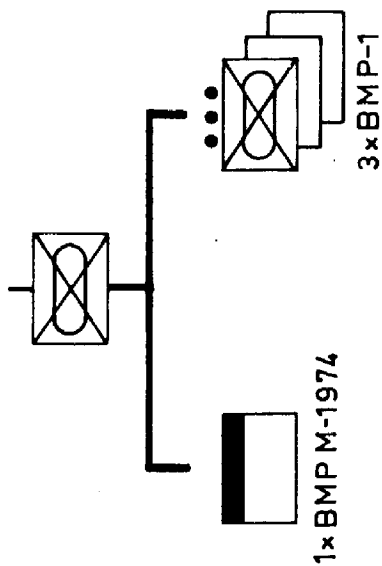

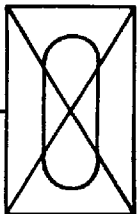

BMP

1	2	3	4	5	6	PERSONEEL	
						Offn	Overigen
Regel	Eenheid						Totaal
1	Staf		2	10	12	5	7
2	Mechpel		1	30	31	4	21
3	Mechpel		1	30	31	4	21
4	Mechpel		1	30	31	4	21
5							
6							
7							
8							
9							
10							
11							
12							
13							
14							
15							
16							
17							
18							
19							
20							
21	Totaal		5	100	105	17	70

7	8	9	10	11	12	13	14	15	16	17	18	19	20	21	22	23	24	25	26	27	28	29	30	31	32	33	34	35	36	37	38	39	40	41						
Pt1	AKM	SYD	PKM	RPG-7	SA-7		BMP-1	BMP K-1974	ZIL-150/151/157	R-105/108/109/114 of R-107/111	R-125M	R-126M																												

# GEMECHANISEERD INFANTERIEREGIMENT (BTR)

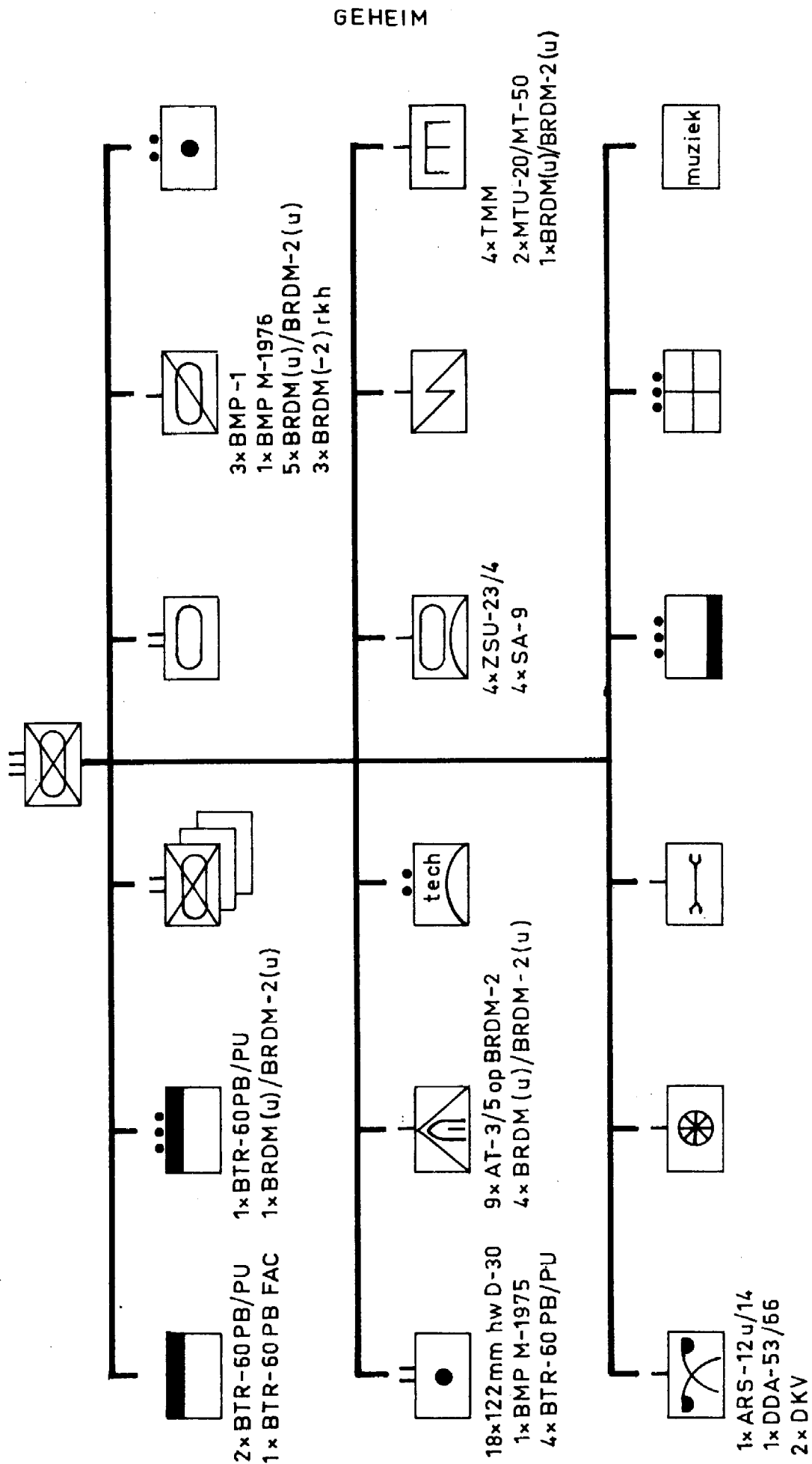

GEHEIM

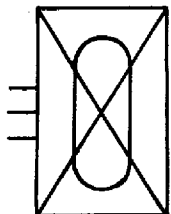

BTR

Regel	Eenheid	PERSONEEL					
		4	5	6	Overigen	Totaal	
1	Staf	33	8	41			
2	Stafpel		29	29			
3	Mechbat(3x)	75	1275	1350			
4	Tkbat	20	197	217			
5	Verkie	4	67	71			
6	Artoegp	1	12	13			
7							
8	Artafd	18	221	239			
9	Atcie	4	36	40			
10	Lustechgp	2	12	14			
11	Mechluabt	4	46	50			
12	Vbacie	2	43	45			
13	Gnoie	4	65	69			
14	Mboicie	2	22	24			
15	Tcie	3	64	67			
16	Onhoie	2	58	60			
17	Vzgpel		21	21			
18	Gnkpel	3	22	25			
19	Musiek	1	20	21			
20							
21	Totaal	176	2218	2396			

RPK	RPG-7	SPG-9	AT-3/4 drbr set	AT-3/5 op BRDM-2	120 mm mr	122 mm hv D-30	ZSU-23/4	SA-7	SA-9	T-55/62/64/72	BMP-1	BMP M-1975 (SMALL FRBD)	BMP M-1976	BMP M-1978/ BTR-60PB/PU	BTR-60PB	BTR-60PB PAC	BRDM(n)/BRDM-2(n)	BRDM(-2) rkh	UAZ-69/469	UAZ-69 rkh	UAZ-452	GAZ-66	ZIL-130/131/157	URAL-375D/377	KFAZ-255(deplader)	Wkplan	Benzen	Rau	Zau (UAZ-451A)	Tekau	Waterauto	PAK-170/200				
7																																				
8																																				
9																																				
10																																				
11																																				
12																																				
13																																				
14																																				
15																																				
16																																				
17																																				
18																																				
19																																				
20																																				
21																																				
22																																				
23																																				
24																																				
25																																				
26																																				
27																																				
28																																				
29																																				
30																																				
31																																				
32																																				
33																																				
34																																				
35																																				
36																																				
37																																				
38																																				
39																																				
40																																				
41																																				

Regel	PERSONEEL					
	1	2	3	4	5	6
1	Star					
2	Stafpel					
3	Mechbat(3x)					
4	Tkbat					
5	Verkie					
6	Arcoogp					
7						
8	Artafd					
9	Atele					
10	Lustechgp					
11	Mechluabt					
12	Ybdcie					
13	Gnoie					
14	Mbecie					
15	Tcie					
16	Onhcie					
17	Vzgpel					
18	Gnkpel					
19	Muziek					
20						
21	Totaal					

	7	8	9	10	11	12	13	14	15	16	17	18	19	20	21	22	23	24	25	26	27	28	29	30	31	32	33	34	35	36	37	38	39	40	41							
M-72/VRAL-3																																										
Abv kenken																																										
Abv water																																										
Abv benzine																																										
Abv diverse																																										
E-54/55T																																										
TMM																																										
MTU-20/MT-55																																										
BTM/MDK-2																																										
BAT/BAT-M																																										
E-305V																																										
PZM																																										
KMT-4/6																																										
KMT-5																																										
PMR-3/60																																										
ARS-12U/14																																										
DDA-53/66																																										
DKV																																										
R-105/108/109/114 of R-107/111																																										
R-118 RM3																																										
R-123M																																										
R-125/145																																										
R-126M																																										
R-311																																										
R-401M/403M																																										
R-405																																										
R-829																																										
PSMR-1																																										

GEMECHANISEERD INFANTERIEBATALJON (BTR)

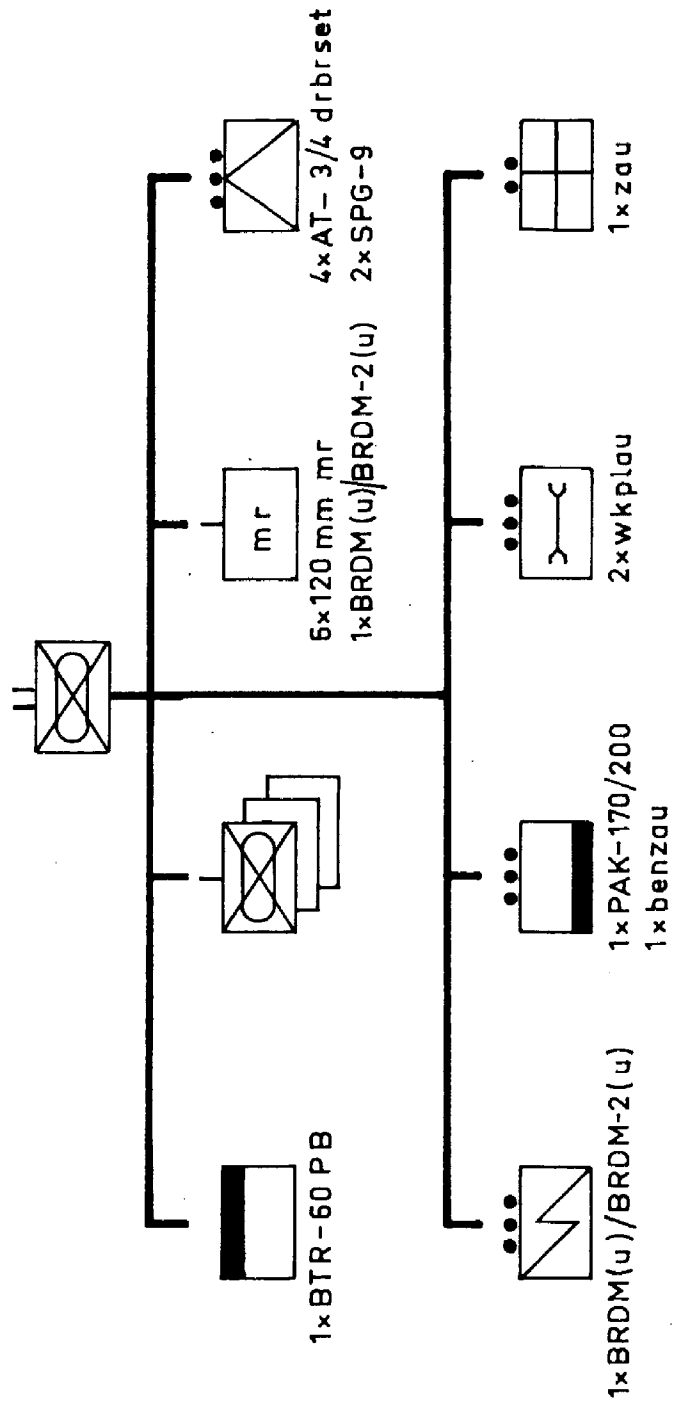



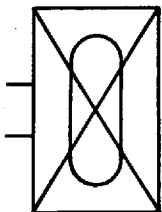

BTR

Regio

1 2 3 4 5 6

PERSONEEL

Offfn Overigen Totaal

4 9 13

1 14 15

5 100 105

5 100 105

5 100 105

4 50 54

1 26 27

13 13

10 10

3 3 3

25 425 450 68 356 9 27 31 2 4 6 9

7 8 9 10 11 12 13 14 15 16 17 18 19 20 21

PEJ ARN STD RPK RFG-1 SPG-9 AT-3/4 drbr set 120 mm nr SA-7 BTR-60PB BTR-60PB/PU BHDW(u)/BHDW-2(u) UAZ-69/469 GAZ-66 ZIL-130/131/157 Wkplan Bessan Rau (GAZ-66) Zan (UAZ-451A) AHW keuken AHW water AHW benzine AHW diverse PAK-170/200

H-105/108/109/114 of H-107/111

H-123M H-126M H-130 H-311

37 38 39 40 41

1984-10-27-177

GEMECHANISEERDE INFANTERIECOMPAGNIE (BTR)

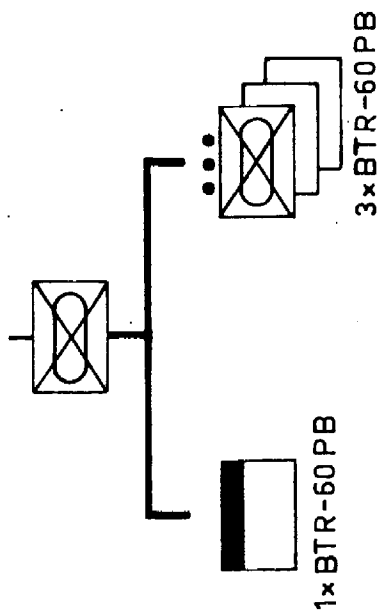

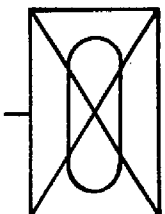

BTR

Regt	Eenheid	PERSONEEL					
		Off'n	Overigen	Totaal			
1	Staf	2	10	12	5	7	
2	Meehpel	1	30	31	4	24	1
3	Meehpel	1	30	31	4	24	1
4	Meehpel	1	30	31	4	24	1
5							
6							
7							
8							
9							
10							
11							
12							
13							
14							
15							
16							
17							
18							
19							
20							
21	Totaal	5	100	105	17	79	3

	7	8	9	10	11	12	13	14	15	16	17	18	19	20	21	22	23	24	25	26	27	28	29	30	31	32	33	34	35	36	37	38	39	40	41			
Pt1																																						
AKM																																						
SYD																																						
RPK																																						
RPG-7																																						
SA-7																																						
BTR-60PB																																						
ZIL-130/131/157																																						
R-105/108/109/114 of R-107/111																																						
R-123M																																						
R-126M																																						

TANKBATALJON (v.h. mechreg)

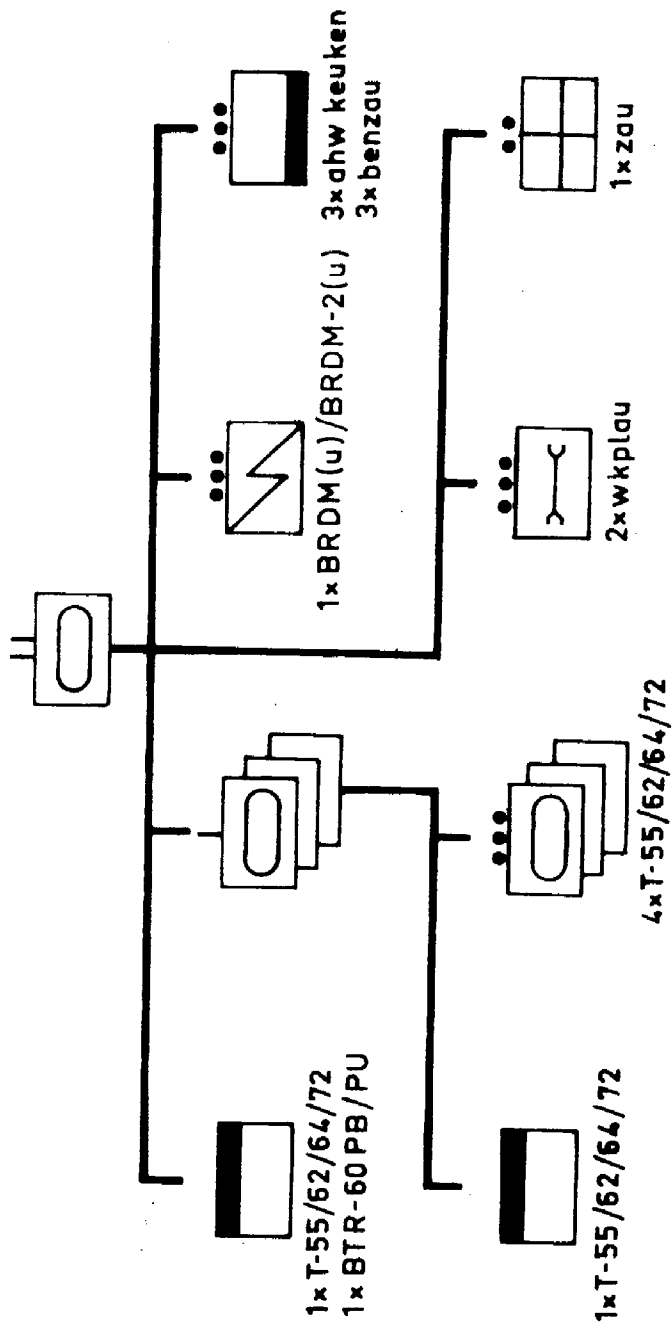



TANKREGIMENT

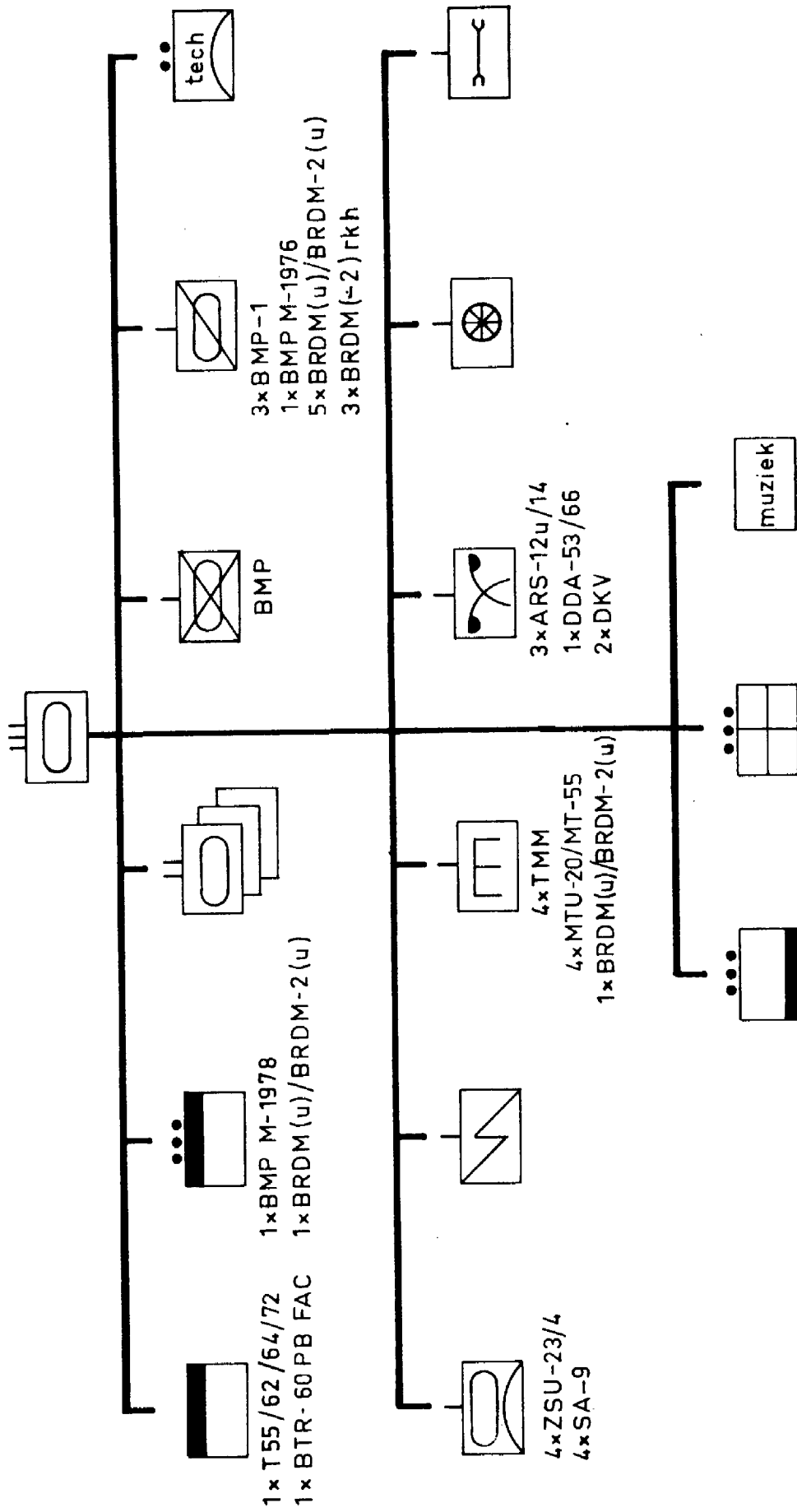

GEHEIM

GEHEIM



1	2	3	4	5	6	7	8	9	10	11	12	13	14	15	16	17	18	19	20	21	22	23	24	25	26	27	28	29	30	31	32	33	34	35	36	37	38	39	40	41							
Regel	Eenheid	PERSONEEL				PKM	RRG-7					ZSU-23/4	SA-7	SA-9	T-55/62/64/72	BMP-1	BMP M-1974	BMP M-1976	BMP M-1978/PU	BRR-60PB PAC	BHDM(n)/BRDM-2(u)	BRDM(-2) rkh	BRR-50BK M-1975	UAZ-69/469	UAZ-69 rkh	GAZ-66	ZIL-130/131/157	URAI-375D/377	KRAZ-255 (dieplader)	Wkplan	Benzen	Hau	Zau(UAZ-451A)	Takan	Waterauto	Pak-170/200											
		Offn	Overigen	Totaal																																											
1	Staf	30	8	38																																											
2	Stafpel		29	29																																											
3	Mkbat(3x)	60	483	543																																											
4	Mecholie	5	100	105																																											
5	Verkoie	4	67	71																																											
6	Lustechgp	2	12	14																																											
7	Mechinabt	4	46	50																																											
8	Vbdcie	2	43	45																																											
9	Gncie	4	65	69																																											
10	Mbcie	2	22	24																																											
11	Toie	3	67	70																																											
12	Onhcie	2	68	70																																											
13	Vzgpel		21	21																																											
14	Gakpel	3	22	25																																											
15	Muziek	1	20	21																																											
16																																															
17																																															
18																																															
19																																															
20																																															
21	Totaal	122	1073	1195	18		22				4	6	4	4	94	12	1	1	11	1	11	3	1	18	3	27	64	34	4	21	29	7	7	2	4	2											





TANKBATALJON

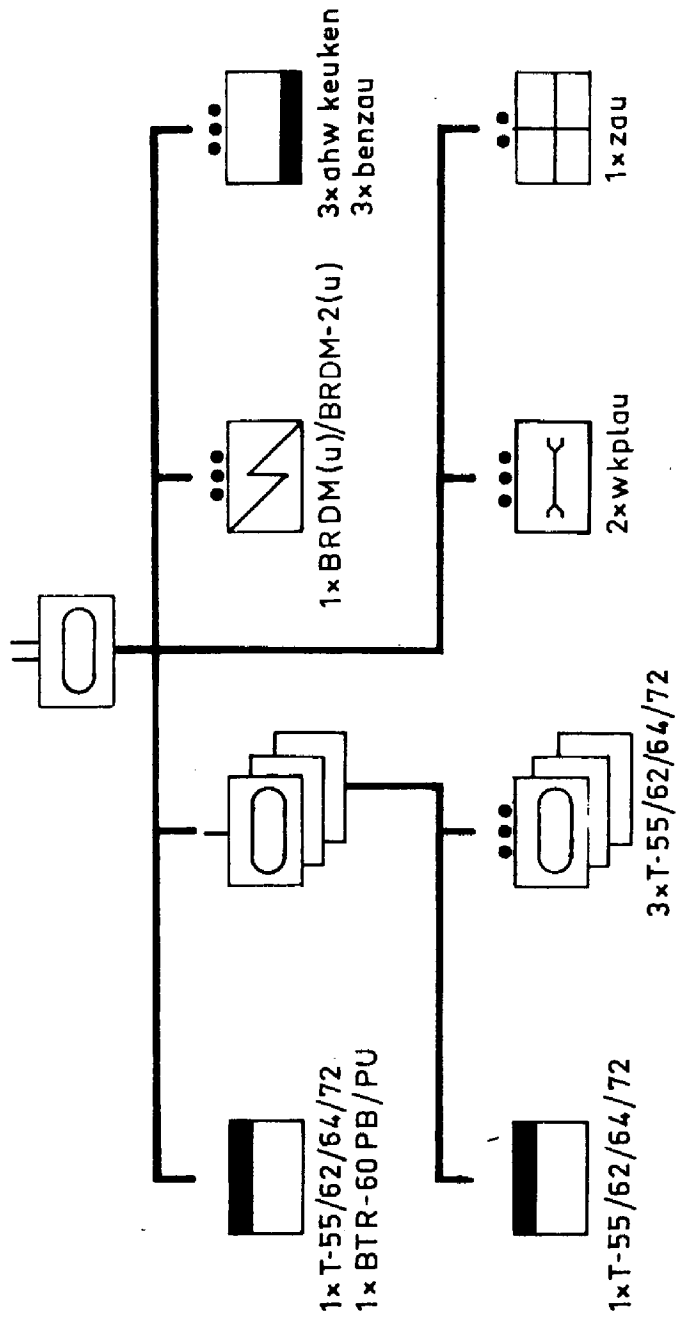

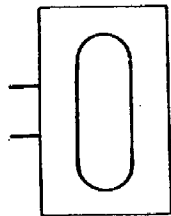

Regel	Eenheid	PERSONEEL					
		Offn	Overigen	Totaal	1)	2)	
1	Staf	4	9	13	8	5	
2	Vbdpel	1	11	12	1	11	
3	Tkcie	5	38	43	5	38	
4	Tkcie	5	38	43	5	38	
5	Tkcie	5	38	43	5	38	
6	Vzgpel		16	16	16		
7	Onhpel		8	8	8		
8	Gak&P	3	3	3	1	2	
9							
10							
11							
12							
13							
14							
15							
16							
17							
18							
19							
20							
21	Totaal	20	161	181	25	156	1

	7	8	9	10	11	12	13	14	15	16	17	18	19	20	21	22	23	24	25	26	27	28	29	30	31	32	33	34	35	36	37	38	39	40	41					
PERI																																								
AKM																																								
R-55/62/64/72											1	1																												
BPR-60PB/PV												1																												
BROD(u)/BRDM-2(u)													1																											
UAZ-69/469															1																									
GAZ-66																																								
ZIL-130/131/157																	1																							
WkPlan																																								
Benzan																																								
Rau(GAZ-66)																																								
Zau(UAZ-451A)																																								
Ahv kenken																																								
Ahv water																																								
Ahv diverse																																								
KMT-4/6																																								
KMT-5																																								
R-105/108/109/114																																								
of R-107/111																																								
R-123M																																								
R-311																																								

1) Indien het tkbat is uitgerust met T-64 of T-72 zijn deze getallen resp. 131 en 150

VERKENNINGSBATALJON

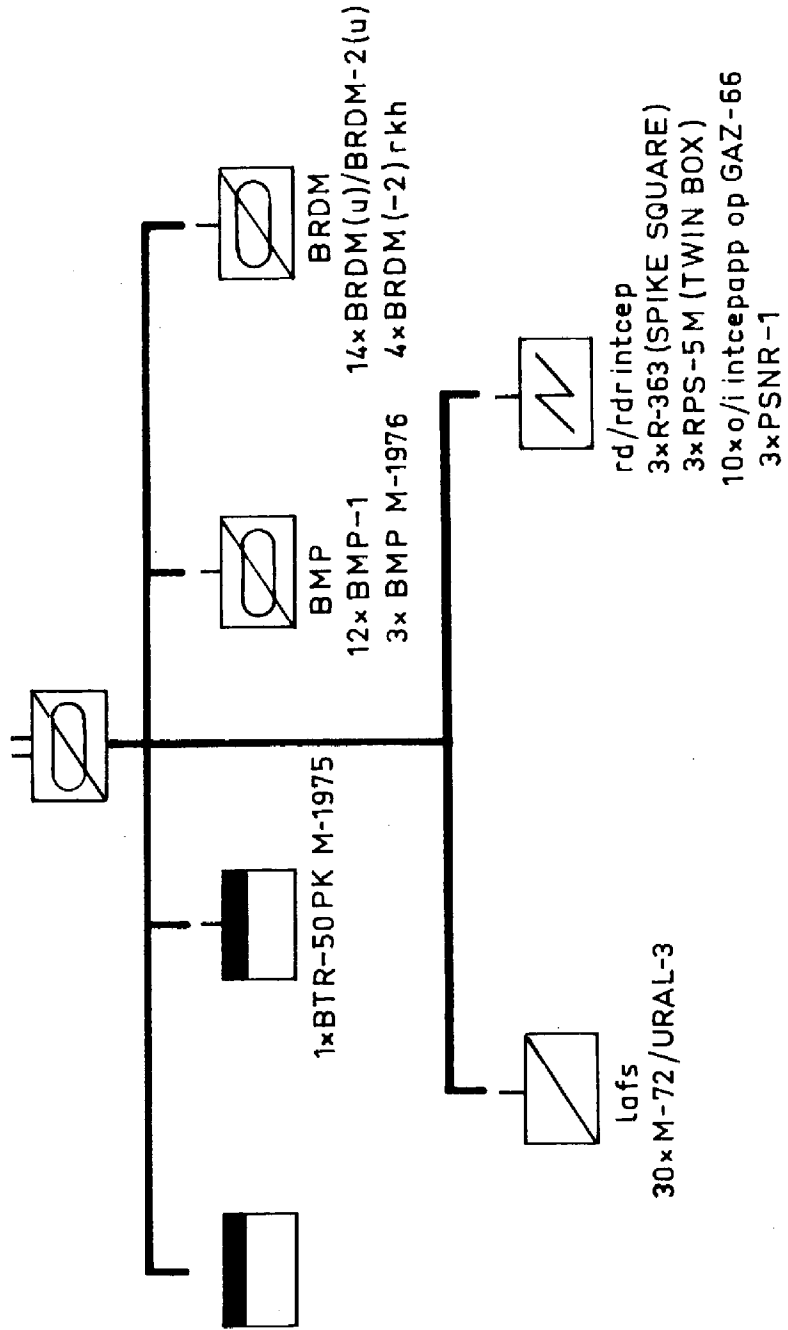

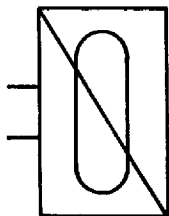

Regd	Eenheid	PERSONEEL					
		1	2	3	4	5	6
1	Staf	10	26	36			
2	Stafoie	2	38	40			
3	Verkoie (BMP)	6	87	93			
4	Verkoie (BRDM)	5	55	60			
5	Verkoie (Iafa)	5	60	65			
6	Vbd/verkoie	8	66	74			
7							
8							
9							
10							
11							
12							
13							
14							
15							
16							
17							
18							
19							
20							
21	Totaal	36	532	568			

7	8	9	10	11	12	13	14	15	16	17	18	19	20	21	22	23	24	25	26	27	28	29	30	31	32	33	34	35	36	37	38	39	40	41																
BMP-1																																																		
BMP M-1936			12	3																																														
BMP M-1978 BTR-60PB/PU			2																																															
BRDM(u)/BRDM-2(u)																																																		
BRDM(-2) rkh																																																		
BTR-50PK M1975																																																		
UAZ-69/469																																																		
GAZ-66																																																		
ZIL-130/131/157																																																		
UBAL-375D/377																																																		
Wkplan																																																		
Bensan																																																		
Rau																																																		
Zmu(UAZ-451A)																																																		
M-72/URAL-3																																																		
Ahv water																																																		
Ahv benzine																																																		
Ahv diverse																																																		
R-105/108/109/114 of R-107/111																																																		
R-118 BR3																																																		
R-123M																																																		
R-125/145																																																		
R-131																																																		
R-311																																																		
R-312/313/314/323																																																		
R-363(SPIKE SQUARE)																																																		
RFS-5M(TWIN BOX)																																																		
9/1 Inteppp (op GAZ-66)																																																		
RA01M/403M																																																		
PSNR-1																																																		

TANKBATALJON (zelfst)



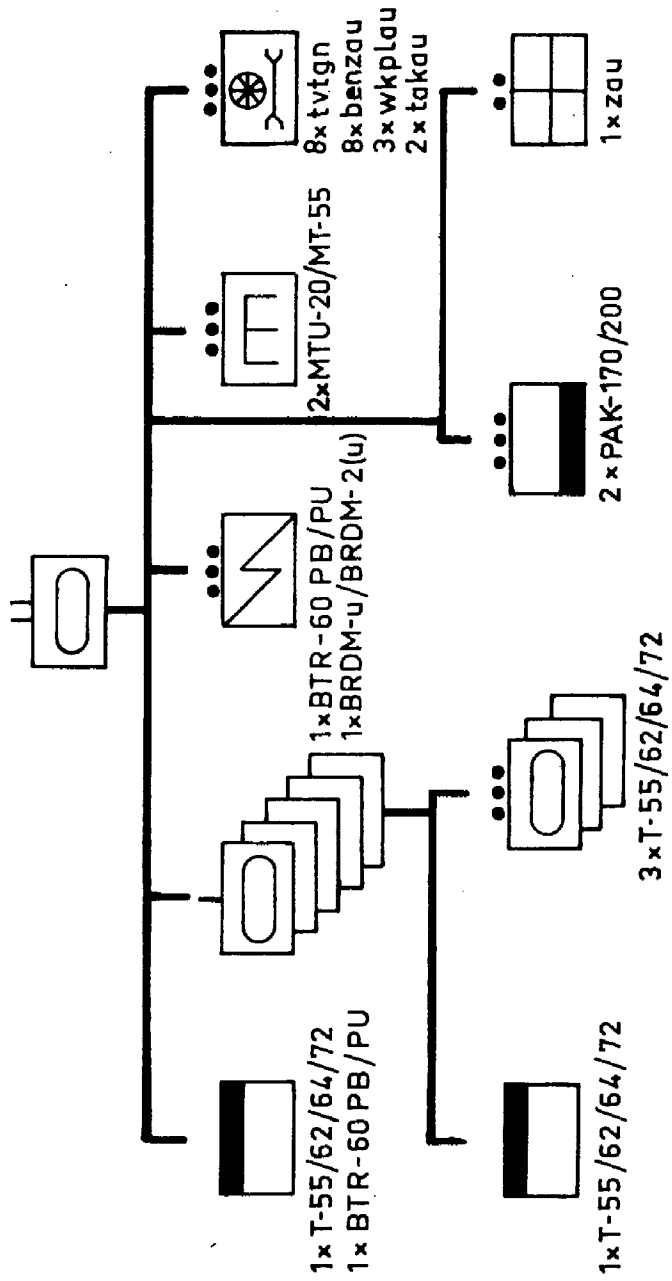

ARTILLERIEREGIMENT (div)

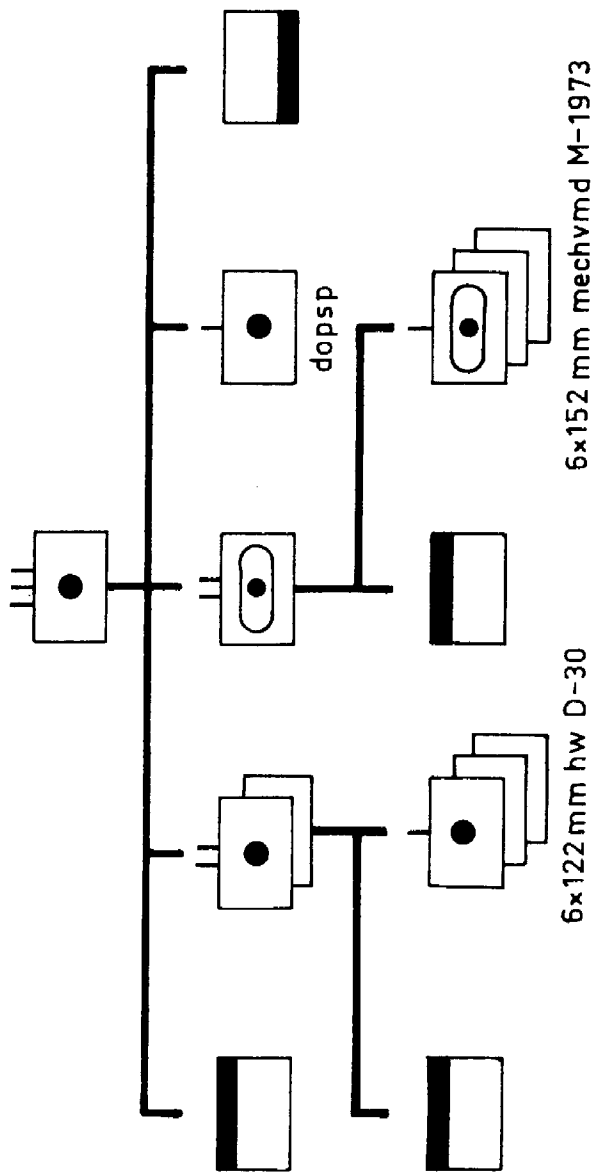







FROG AFDELING

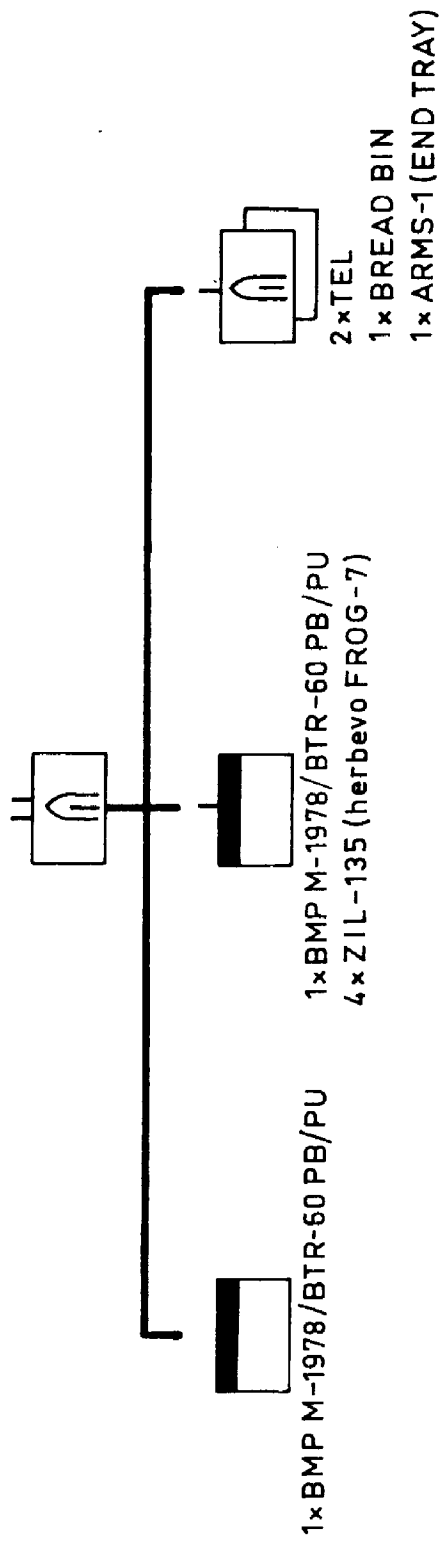

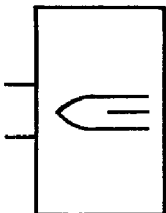

FROG

Regel	Eenheid	PERSONEEL					
		1	2	3	4	5	6
1	1 Staf		10	8	18		
2	2 Stafbt		5	73	78		
3	3 Rkbt		4	36	40		
4	4 Rkbt		4	36	40		
5							
5							
7							
8							
9							
10							
11							
12							
13							
14							
15							
16							
17							
18							
19							
20							
21	Totaal	23	153	176	4		

	7	8	9	10	11	12	13	14	15	16	17	18	19	20	21	22	23	24	25	26	27	28	29	30	31	32	33	34	35	36	37	38	39	40	41					
Prog-7 TEL																																								
BMD M-1978/BR-60PB/PU			1																																					
UAZ-69/469				1																																				
UAZ-452					1	1	1	9	6	4																														
GAZ-66											2	2																												
ZIL-130/131/157																																								
URAL-375D/377																																								
ZIL-135 (herbevo Prog-7)																																								
Kraanauto																																								
Wipplan																																								
Benzan																																								
Zan																																								
Ahv keuken																																								
Ahv water																																								
Ahv benzine																																								
Ahv diverse																																								
R-105/108/109/114 of R-107/111																																								
R-118 BM3																																								
R-125/145																																								
R-311																																								
R-512/313/314/323																																								
R-401M/403M																																								
BREAD BIN																																								
ARMS-1 (BMD TRAY)																																								

GEHEIM

RAKETWERPERAFDELING

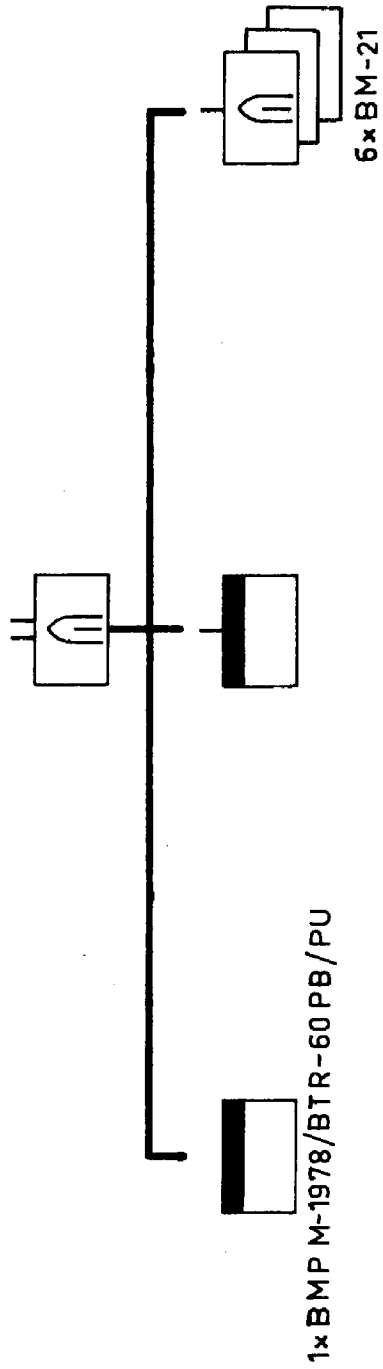

GEHEIM

LAS'79 / &V379



ANTITANK AFDELING

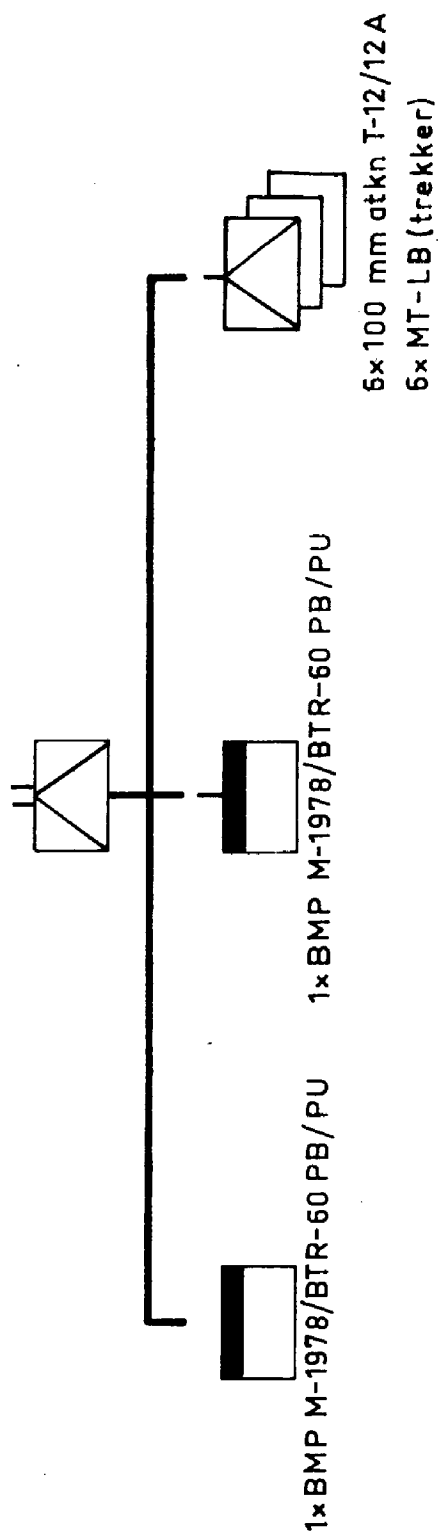

	7	8	9	10	11	12	13	14	15	16	17	18	19	20	21	22	23	24	25	26	27	28	29	30	31	32	33	34	35	36	37	38	39	40	41				
76 mm atkn ZIS-3																																							
100 mm atkn P-12/12A BMP M-1978/ PTR-60PB/PU																																							
MT-LB (trekker)																																							
UAZ-69/469																																							
GAZ-66																																							
ZIL-130/131/157																																							
URAL-375D/377																																							
Wkplau																																							
Benzau																																							
Rau																																							
Zau																																							
Ahv keuken																																							
Ahv water																																							
Ahv benzine																																							
Ahv diverse																																							
R-102M/103M																																							
R-105/108/109/114 of R-107/111																																							
R-123M																																							
R-125/145																																							
R-311																																							
R-401M/403M																																							
PSNR-1																																							
DAK-1																																							

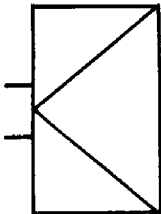

Regel	Eenheid	PERSONEEL					
		4	5	6	Overigen	Totaal	
1	Staf	5	6	11			
2	Staflbt	3	42	45			
3	Atbt	5	66	71			
4	Atbt	5	66	71			
5	Atbt	5	66	71			
6							
7							
8							
9							
10							
11							
12							
13							
14							
15							
16							
17							
18							
19							
20							
21	Totaal	23	246	269			

SA-6 REGIMENT

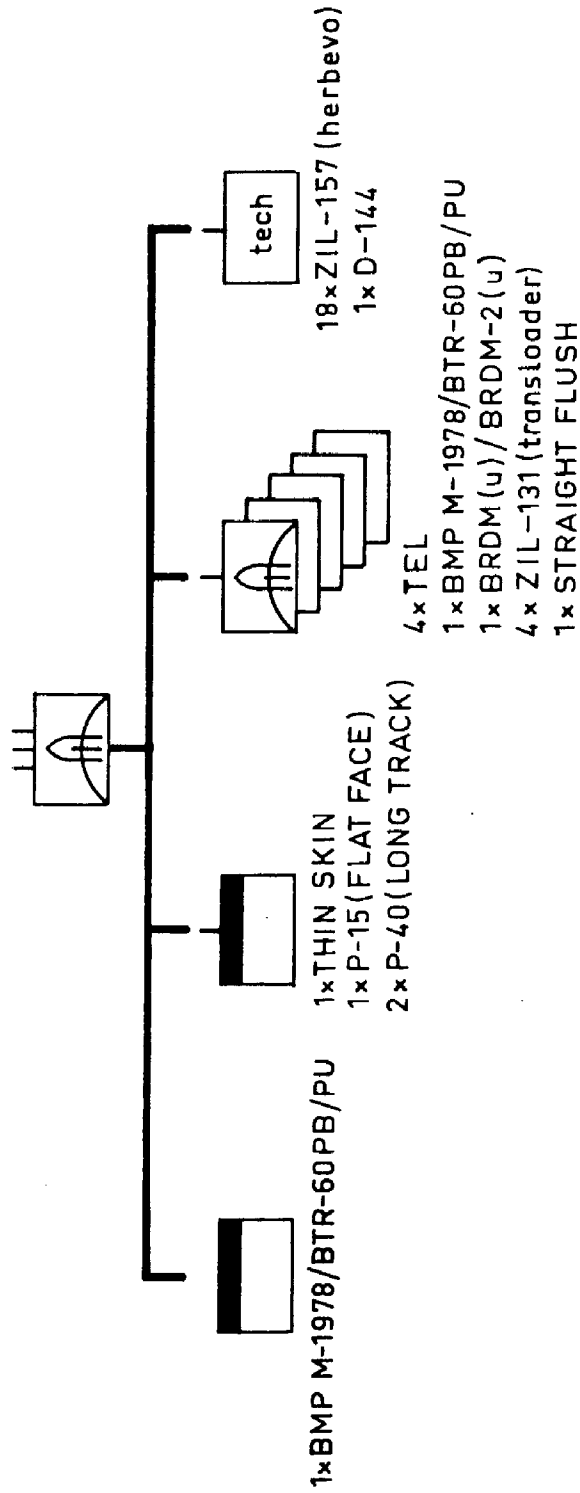



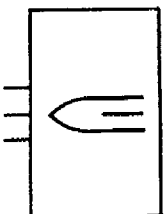

SA-6

Regd	Eenheid	PERSONEEL					
		3	4	5	6	Offn/Ovengeftotaal	
1	1 Staf	8	8	20	28		
2	2 Stafbt	8	8	110	118		
3	3 SA-6 bt	8	8	40	48		
4	4 SA-6 bt	8	8	40	48		
5	5 SA-6 bt	8	8	40	48		
6	6 SA-6 bt	8	8	40	48		
7	7 SA-6 bt	8	8	40	48		
8	8 Tech bt	8	8	65	73		
9							
10							
11							
12							
13							
14							
15							
16							
17							
18							
19							
20							
21	<b>Totaal</b>	64	64	395	459		

	7	8	9	10	11	12	13	14	15	16	17	18	19	20	21	22	23	24	25	26	27	28	29	30	31	32	33	34	35	36	37	38	39	40	41							
SA-6 TEL																																										
SA-7																																										
BMR M-1978/ BRM 60PB/EU							1																																			
BRDM(n)/BRDM-2(u)										2																																
VZ-69/469																																										
VZ-452																																										
GAZ-66																																										
ZIL-130/131/157																																										
UHAI-375D/377																																										
ZIL-131 (transloader SA-6)																																										
ZIL-157 (herbvo SA-6)																																										
Kraanauto																																										
Wpjan																																										
Benzaan																																										
Rkbrstaato																																										
Rau																																										
Zau																																										
Waterauto																																										
Ahv keuken																																										
Ahv water																																										
Ahv benzine																																										
Ahv rkrbst																																										
Ahv diverse																																										
D-144																																										

7	8	9	10	11	12	13	14	15	16	17	18	19	20	21	22	23	24	25	26	27	28	29	30	31	32	33	34	35	36	37	38	39	40	41			
				R-105/108/109/114 of R-107/111	R-118 RM3	R-123M	R-125/145	R-311	R-401M/403M	R-409(CATS EYE)					THIN SKIN		P-15 (FLAT FACE)	P-40 (LONG TRACK)	STRAIGHT FLUSH																		

Regel	Eenheid	PERSONEEL					
		Offn	Overigen	Totaal			
1	Staf						
2	Stafbt						
3	SA-6 bt						
4	SA-6 bt						
5	SA-6 bt						
6	SA-6 bt						
7	SA-6 bt						
8	Tech bt						
9							
10							
11							
12							
13							
14							
15							
16							
17							
18							
19							
20							
21	Totaal	8	1	6	4	1	1

SA-8 REGIMENT

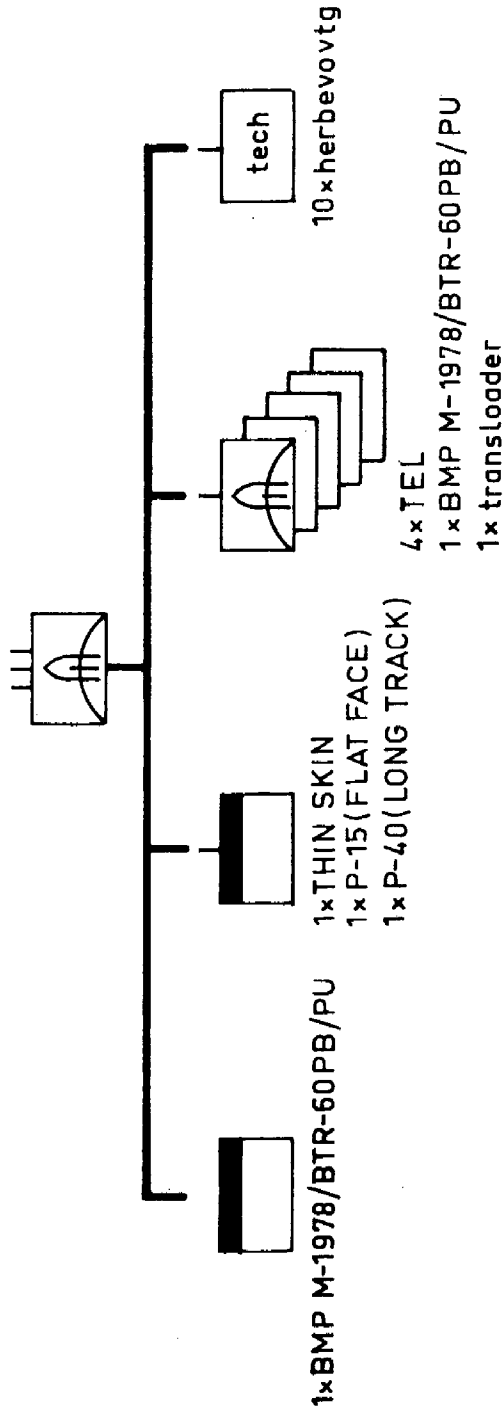





GENIEBATALJON

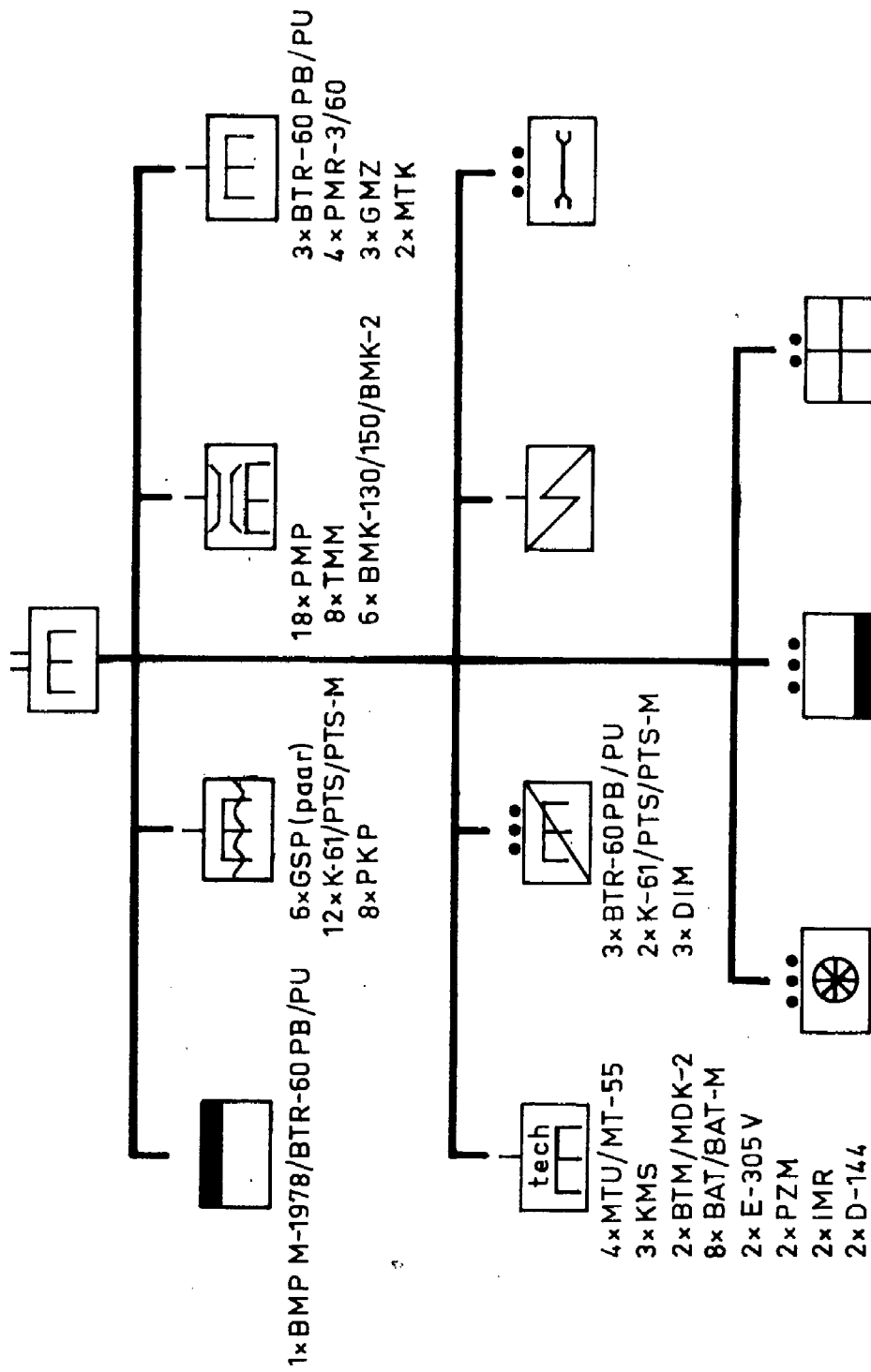

GEHEIM

GEHEIM



	7	8	9	10	11	12	13	14	15	16	17	18	19	20	21	22	23	24	25	26	27	28	29	30	31	32	33	34	35	36	37	38	39	40	41
	RPM/MDK-2	BAT/BAT-M	E-305V	PMZ	IMR	D-144	PMR-3/60	GMZ	MTR	DIM								R-105/108/109/114 of R-107/111	R-123M	R-125/145															

Rege	Eenheid	PERSONEEL																																															
		4	5	6	Orfn/Overgen	Totaal																																											
1	Staf																																																
2	Vbdpel																																																
3	Amfole																																																
4	Pontbrcie																																																
5	Gvldcie																																																
6	Techole																																																
7	Gaverkpel																																																
8	Onhpel																																																
9	Tpel																																																
10	Vzgpel																																																
11	Gakgp																																																
12																																																	
13																																																	
14																																																	
15																																																	
16																																																	
17																																																	
18																																																	
19																																																	
20																																																	
21	Totaal																																																



VERBINDINGSBATALJON

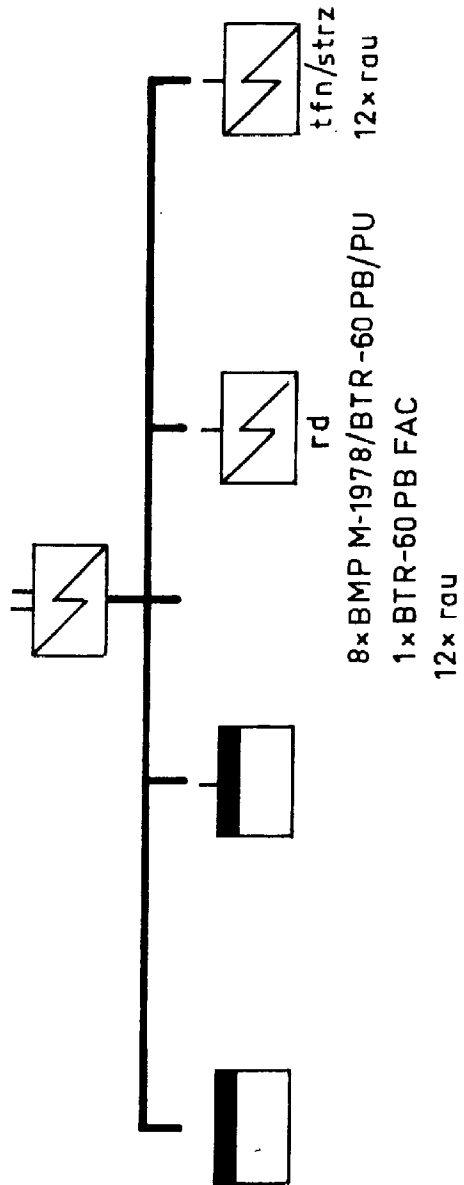

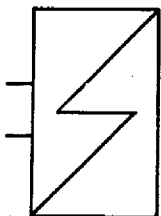

1	2	3	4	5	6	
Regel	Eenheid		PERSONEEL			
			Offn Overig			
				Totaal		
1	Staf		5	5	10	
2	Stafcie		3	50	53	
3	Ydctie (rd)		7	130	137	
4	Ydctie (tfn/strz)		5	100	105	
5						
6						
7						
8						
9						
10						
11						
12						
13						
14						
15						
16						
17						
18						
19						
20						
21	Totaal	20	285	305		

7	8	9	10	11	12	13	14	15	16	17	18	19	20	21	22	23	24	25	26	27	28	29	30	31	32	33	34	35	36	37	38	39	40	41		
	BMP M-1978/ BTR-60PB/PU	BTR-60PB FAC			TAZ-69/469	TAZ-452	GAZ-66	ZIL-130/131/157	Wkplan	Benzan	Hau	Zau	M-72/BRAL-5	Ahv keuken	Ahv water	Ahv benzine	Ahv diverse			R-102M/103M R-105/108/109/114 of R-107/111	R-118 BM3	R-122M (SPRONG REST)		R-125/145	R-140	R-312/313/314/323		R-401M/403M	R-405		R-809/824/829					
	8	1			4	9	7	5	4	2	12	1	13	2	1					4	15	6	1		14	2	1			6						
	8	1			18	1	7	11	4	2	24	1	13	2	1	4	31	4	4	30	6	1	14	2	1	6		6						5		

NBC BATALJON

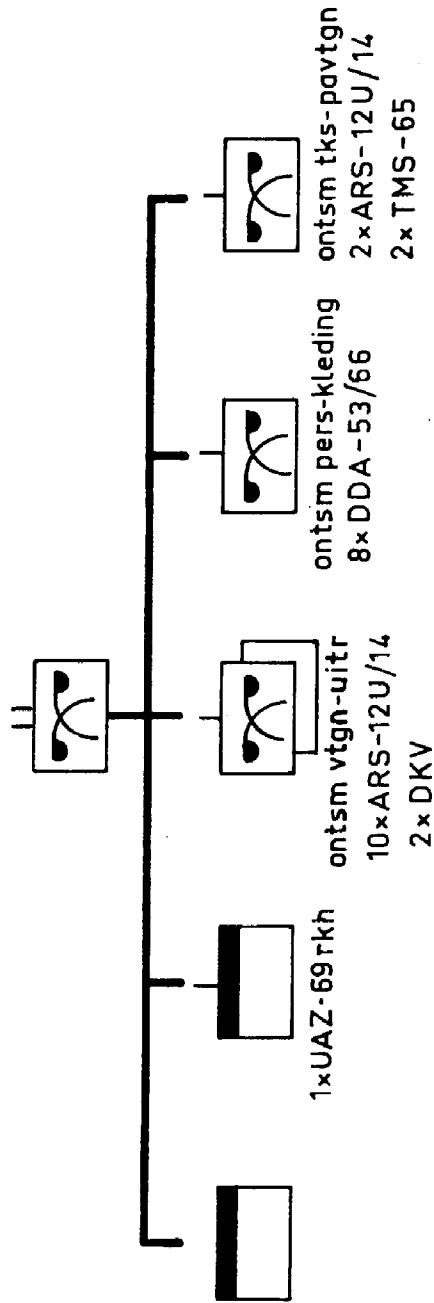

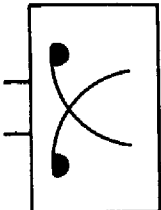

1	2	3	4	5	6	PERSONEEL		7	8	9	10	11	12	13	14	15	16	17	18	19	20	21	22	23	24	25	26	27	28	29	30	31	32	33	34	35	36	37	38	39	40	41												
						Offn/Overigen	Totaal																																															
Regd	Eenheid																																																					
1	1 Staf		4	10	14	1																																																
2	2 Stafople		3	51	54	1																																																
3	3 Ontsmoie (vign-uitr)		2	30	32	1																																																
4	4 Ontsmoie (vign-uitr)		2	30	32	1																																																
5	5 Ontsmoie (pers-Meddg)		2	28	30	1																																																
6	6 Ontsmoie (tks-pavtgr)		1	14	15	1																																																
7																																																						
8																																																						
9																																																						
10																																																						
11																																																						
12																																																						
13																																																						
14																																																						
15																																																						
16																																																						
17																																																						
18																																																						
19																																																						
20																																																						
21	Totaal		14	163	177	5																																																

GEHEIM

GENEESKUNDIG BATALJON

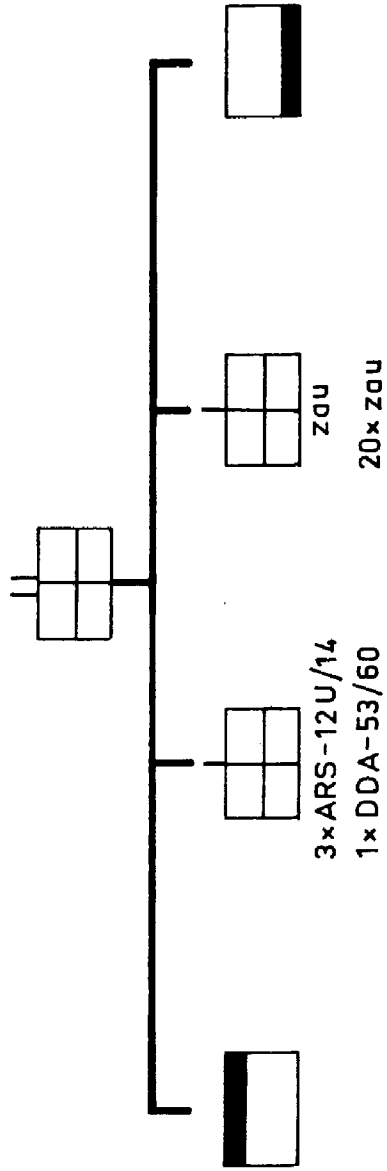

GEHEIM

Reper 1	Eenheid 2	PERSONEEL						7	8	9	10	11	12	13	14	15	16	17	18	19	20	21	22	23	24	25	26	27	28	29	30	31	32	33	34	35	36	37	38	39	40	41
		Offin	Overigen	Totaal																																						
1	Staf	3	4	7	1		UAZ-69/469																																			
2	Onkoie	23	60	83	1																																					
3	Zaucie	2	43	45	1									20																												
4	Diensten	2	60	62	1																																					
5																																										
6																																										
7																																										
8																																										
9																																										
10																																										
11																																										
12																																										
13																																										
14																																										
15																																										
16																																										
17																																										
18																																										
19																																										
20																																										
21	Totaal	30	167	197	4	12	31					2	2	20	3		4	4	2	20				3	3	1																

GEHEIM

TRANSPORT BATALJON

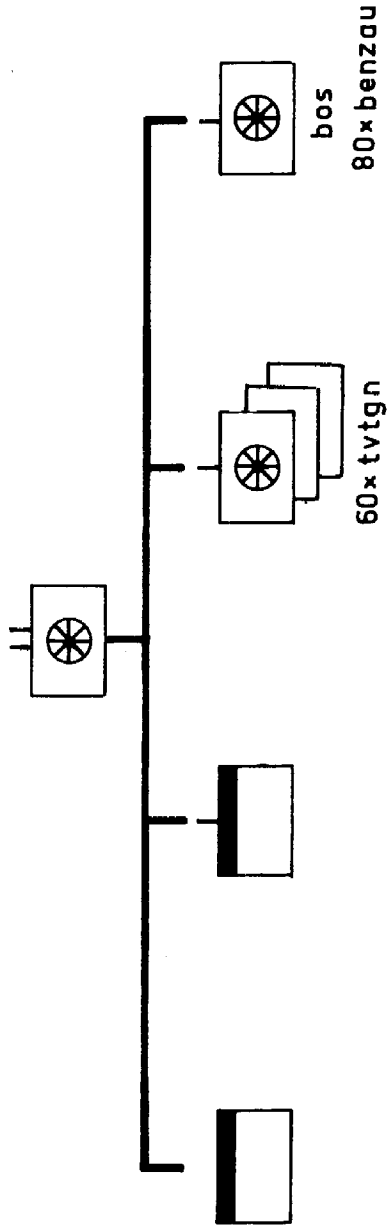

GEHEIM

LAS 79 / EV 388





ONDERHOUDSBATALJON

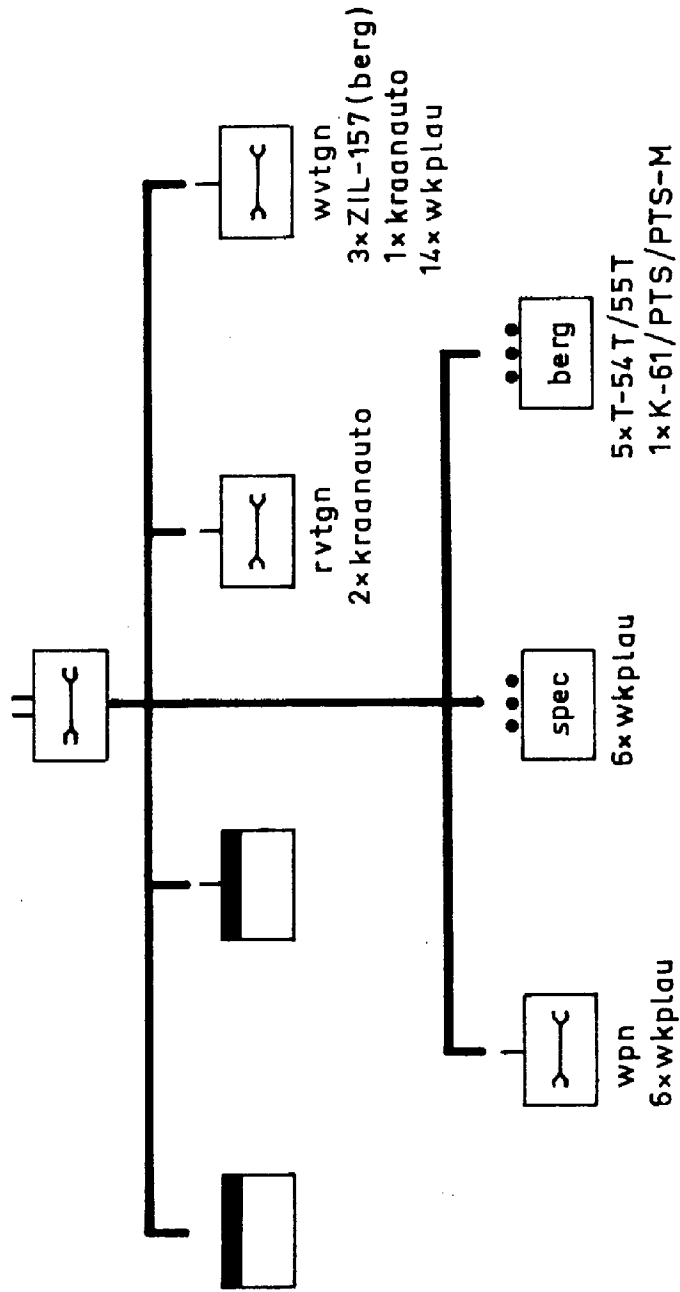

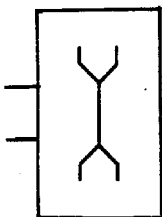

	7	8	9	10	11	12	13	14	15	16	17	18	19	20	21	22	23	24	25	26	27	28	29	30	31	32	33	34	35	36	37	38	39	40	41																					
VZ-69/469																																																								
GAZ-66				ZII-130/131/157																																																				
KAZ-258 (dieplader)																																																								
ZII-157 (bergine)																																																								
Kraanauto																																																								
Wkplan																																																								
Benzau																																																								
Zau																																																								
Waterauto																																																								
M-72/URAL-3																																																								
Ahv kenken																																																								
Ahv water																																																								
Ahv benzine																																																								
Ahv diverse																																																								
T-54T/55T																																																								
K-61/PTS/PTS-M																																																								
R-105/108/109/114 of R-107/111																																																								
R-123M																																																								
R-126M																																																								
R-311																																																								

Regel	Eenheid	PERSONEEL					
		Offin	Overig	Totaal			
1	Staf	6	4	10	2		
2	Stafolie	1	24	25			
3	Onhoie rvtign	4	50	54			
4	Onhoie vrtign	4	66	70			
5	Onhoie wjn	2	38	40	1		
6	Speepel	1	25	26			
7	Bergpel	1	14	15			
8							
9							
10							
11							
12							
13							
14							
15							
16							
17							
18							
19							
20							
21	Totaal	19	221	240			

# LUCHTLANDINGSDIVISIE

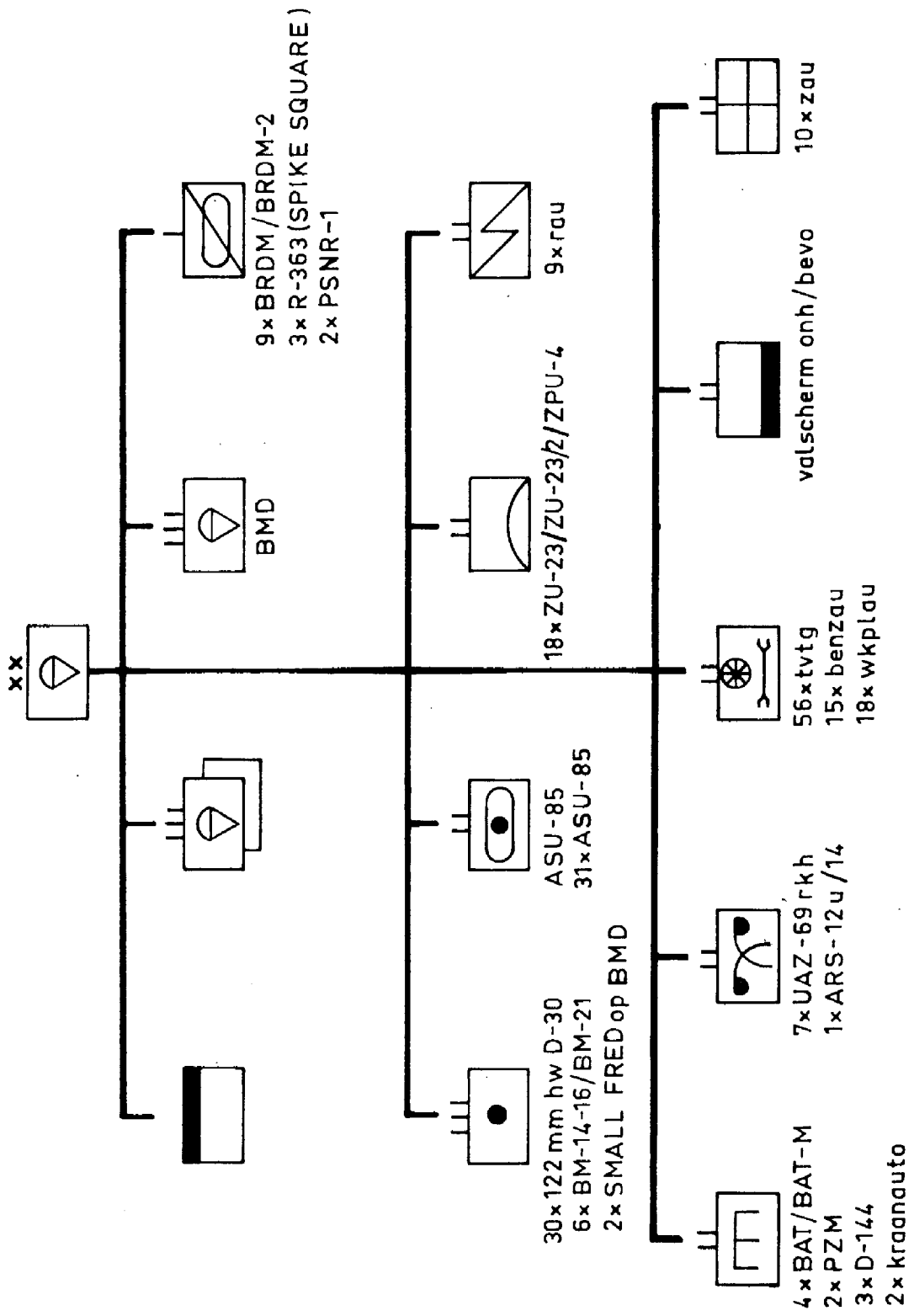

GEHEIM

GEHEIM





LUCHTLANDINGSREGIMENT

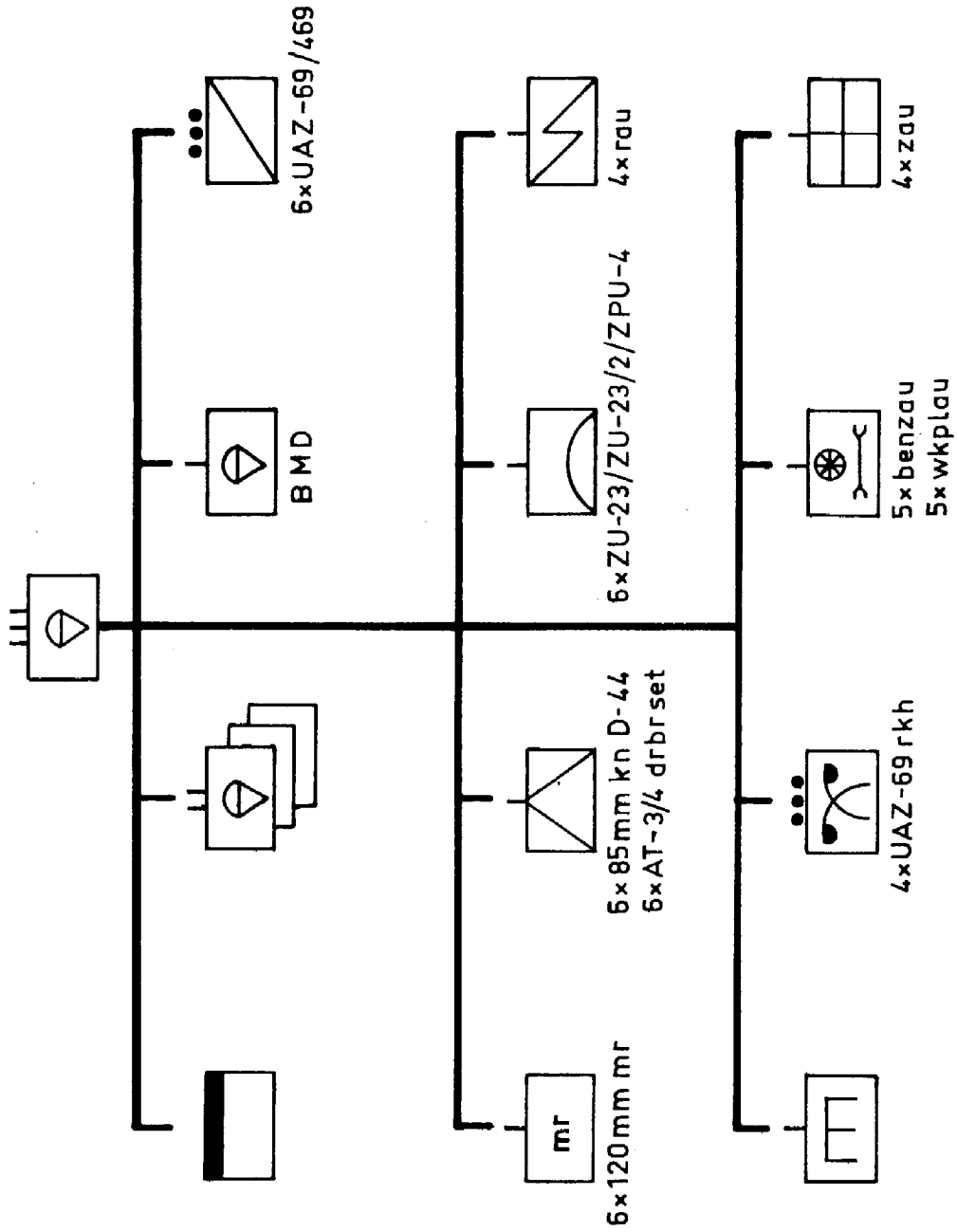

GEHEIM

GEHEIM



LUCHTLANDINGSREGIMENT (BMD)

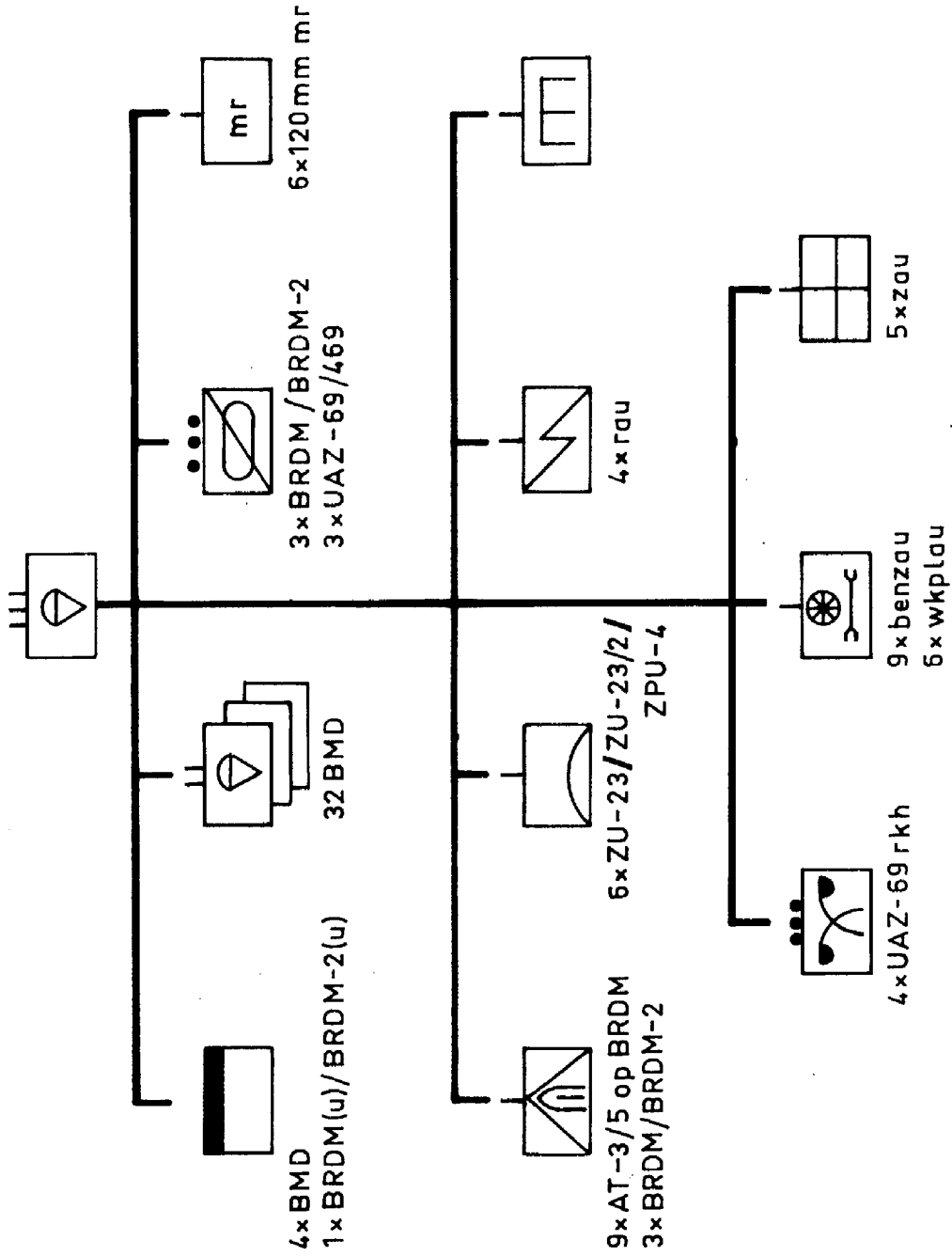

GEHEIM

GEHEIM



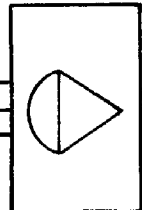

BMD

Regele	PERSONNEEL					
	1	2	3	4	5	6
Eenheden	30	81	111			
Offn Overigt	22	308	330			
Totaal	22	308	330			
	22	308	330			
	2	30	32			
	5	50	55			
	5	52	57			
	4	51	55			
	5	52	57			
	4	63	67			
	1	20	21			
T- en Onhoie	9	94	103			
Onknie	8	28	36			
Totaal	139	1445	1584			

	7	8	9	10	11	12	13	14	15	16	17	18	19	20	21	22	23	24	25	26	27	28	29	30	31	32	33	34	35	36	37	38	39	40	41							
RPG-7D/V																																										
AT-3/5 op BRDM																																										
120 mm nr																																										
ZU-23/ZU-23/2/ZPU-4																																										
SA-7																																										
BMD																																										
BRDM(V)/BRDM-2(V)																																										
UAZ-69/469																																										
UAZ-69 rkh																																										
GAZ-66																																										
ZII-130/131/137/URAL-375D/377																																										
Benzan																																										
Rau																																										
Zau																																										
Ahv keuken																																										
Ahv water																																										
Ahv diverse																																										
R-105/108/109/114 of R-107/111																																										
R-118 BM3																																										
R-123M																																										
R-125/145																																										
R-126/116																																										
R-311																																										
R-809/824/829																																										

LUCHTLANDINGSSTORMBRIGADE

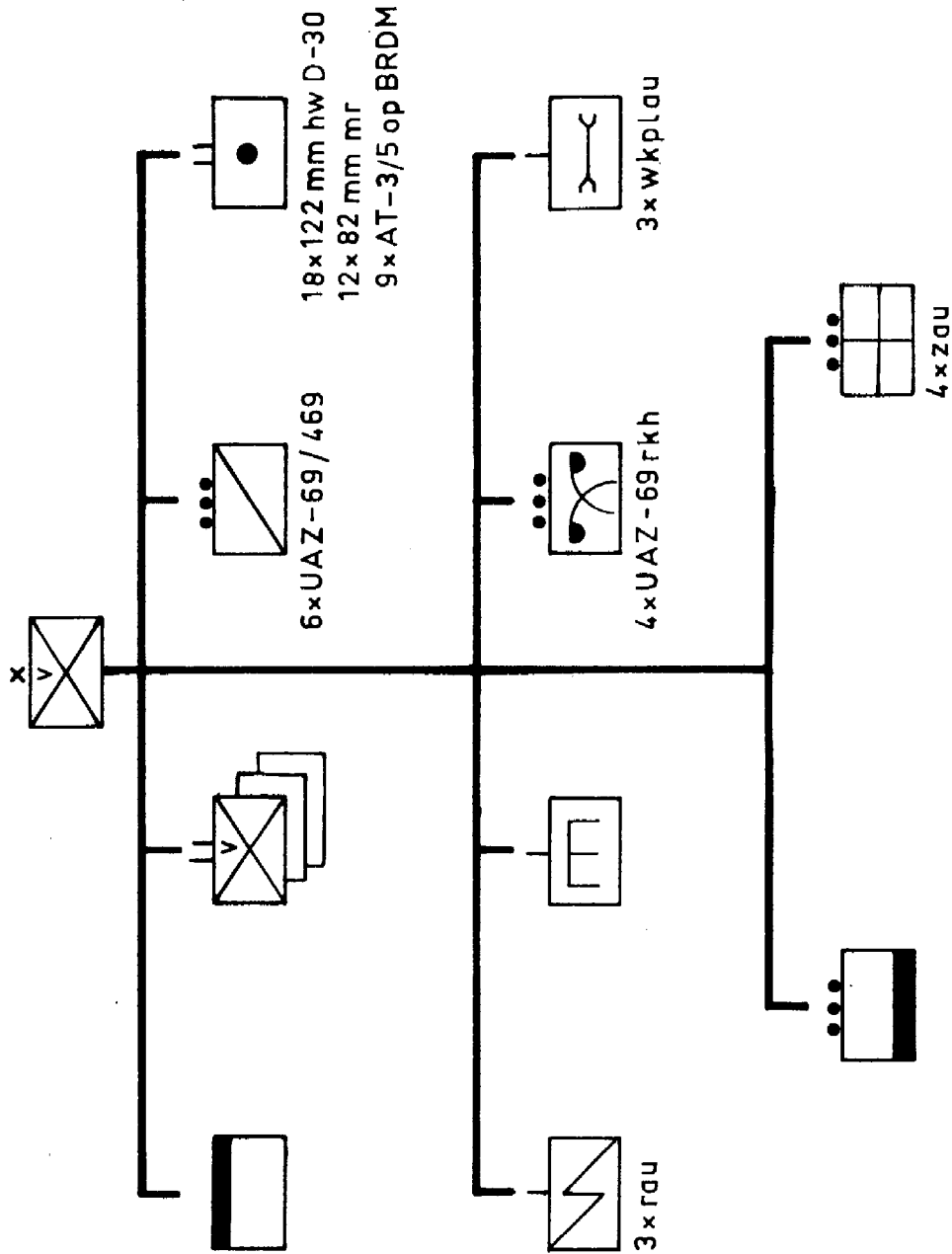



# MARINE INFANTERIEREGIMENT

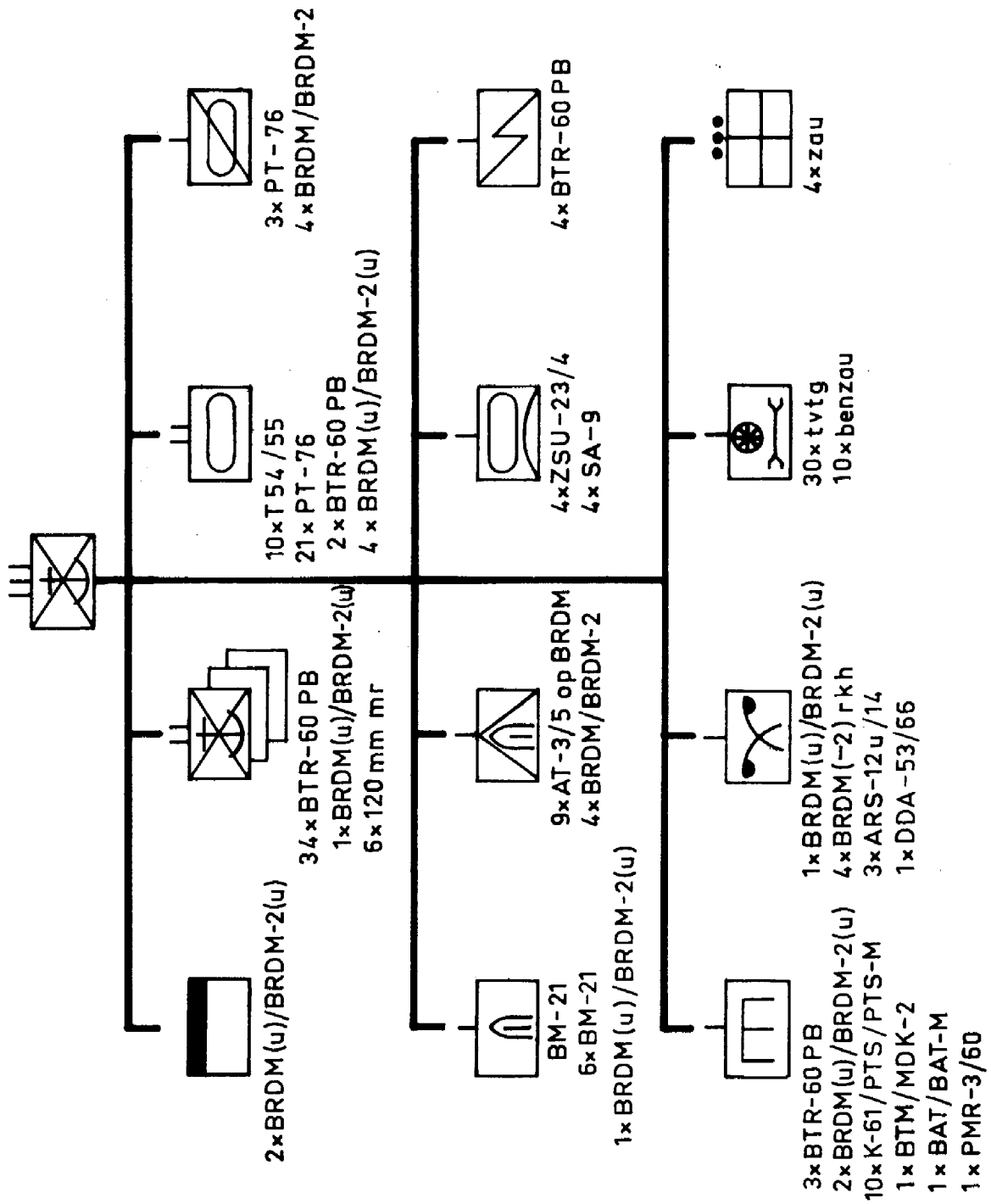

GEHEIM

GEHEIM

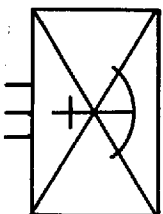

1	2	3	4	5	6	PERSONEEL	
						Offn	Totaal
1	Staf		33	37	70		
2	Marinbat		25	385	410		
3	Marinbat		25	385	410		
4	Marinbat		25	385	410		
5	Tkbat		22	145	167		
6	Verkele		3	47	50		
7	Rkwbt		5	57	62		
8	Abbt		4	42	46		
9	Luabt		5	57	62		
10	Vbdcie		5	45	50		
11	Gncie		9	101	110		
12	Mbecie		6	44	50		
13	T- en Onhele		6	114	120		
14	Gnkpel		8	22	30		
15							
16							
17							
18							
19							
20							
21	<b>Totaal</b>		181	1866	2047		

7	8	9	10	11	12	13	14	15	16	17	18	19	20	21	22	23	24	25	26	27	28	29	30	31	32	33	34	35	36	37	38	39	40	41	
	RFG-7	AT-3/4 drbr set	AT-3/5 op BRDM	120 mm mr	BM-21	ZSU-23/4	SA-7	SA-9		T-54/55	PT-76	BTR-60 PB	BRDM(u)BRDM-2(u)	BRDM(-2) rkh		VAZ-69/469	GAZ-66	ZIL-130/131/157/URAL-375D/377	Trekker		Benzau	Zau	Ahw keuken	Ahw water	Ahw diverse	T-54R/55R		K-61/PFS/PFS-M	BTM/MDK-2	BAT/BAT-M	PMR-3/60		ARS-12U/14		DDA-53/66